

UNIVERSAL TURRET MILLIG MACHINE

OPERATING MANUAL

MODEL: _____

SERIAL NO.: _____

DATE: _____

Geometric Accuracy

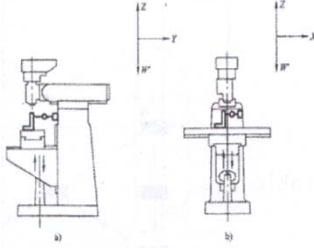
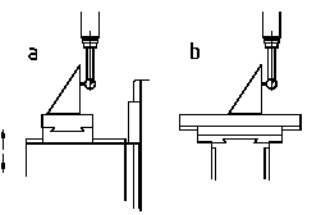
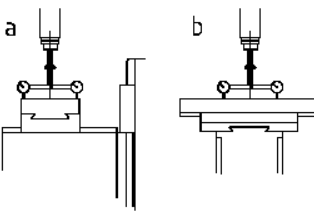
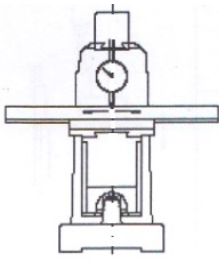
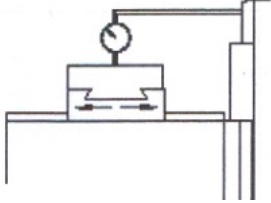
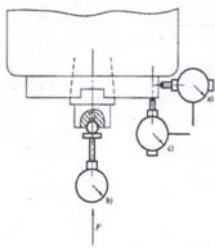
No.	Inspection item		Diag.	Tolerance	Actual
1	Straightness of knee vertical movement	a) in Y-Z surface		0.025/300	
		b) in X-Z surface			
2	Squareness of upper surface of table to knee movement	Right and left direction		0.025/300	
		Forward and backward direction		0.025/300	
3	Squareness of vertical movement of the spindle head with table surface	Right and left direction		Per 0.020/125	
		Forward and backward direction		0.020/125	
4	Parallelism of right and left movement of table to its upper surface			0.02/300	
5	Parallelism of forward and backward movement of table to its upper surface			0.02/300	
6	End of spindle Run out			0.01	

7	spindle taper hole run-out	end of test bar		0.01	
		Distance 200		0.02	
8	Squareness of surface center line to table surface	Right and left direction		0.025/300	
		Forward and backward direction		0.025/300	
9	Parallelism of right and left movement of table to side of middle T slot of table			0.015/300 max.0.04	
10	Squareness of table cross movement to longitudinal movement			0.02/300	
G12	Parallelism of ram movement to table surface			0.035/300	
G13	Parallelism of ram swivel to table surface			0.035	

Table of Contents

CHAPTER 1. Introduction

1-1 Front view of machine.....	1
1-2 Machine main data sheet.....	2

CHAPTER 2. Safety

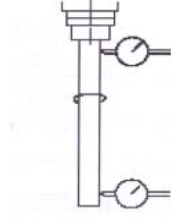
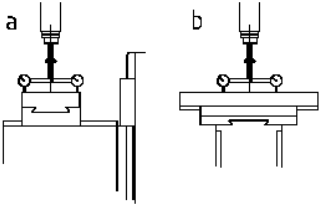
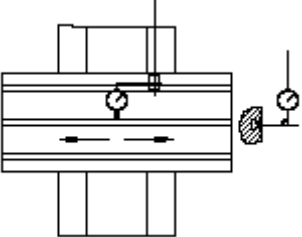
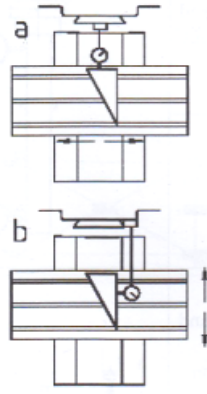
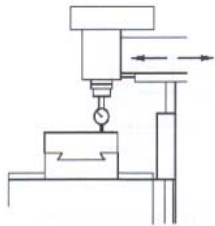
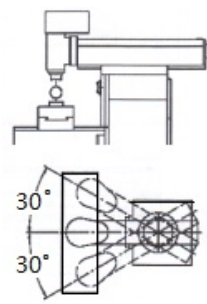
2-1 Safety instruction for machine.....	3
2-2 Important safety information of the machine	3
2-3 Safety rules during and/or before operations	8
2-4 Safety rules during electrical connection or disconnection	9

CHAPTER 3. Installation

3-1 Safety precautions.....	11
3-2 Unpacking and cleaning.....	11
3-3 Checking standard accessories.....	12
3-4 Machine dimension.....	14
3-5 Foundation.....	15
3-6 Lift and placing.....	16
3-7 Power supply.....	17
3-8 Align the milling head.....	17

CHAPTER 4. Operations

4-1 Position the ram	19
4-2 Locking the table, saddle, and knee.....	20

CHAPTER 5. Operations of milling head

5-1 Operating levers instruction.....	21
5-2 Spindle speed selecting.....	23
5-3 Spindle down feed.....	25
5-4 Swing milling head forward or backward.....	27
5-5 Swing milling head right or left.....	27

CHAPTER 6. Maintenance

6-1 Adjusting gibs.....	28
6-2 Adjust lead screw back lash.....	29

6-3 lubrication.....	30
6-4 quill reverse spring replacement.....	32
6-5 replace motor, belt and brake assy. Of variable speed milling head.....	33
6-6 replace motor, belt and brake assy. Of step speed milling head.....	35

CHAPTER 7. Parts list

7-1 Parts list of machine body.....	38
7-2 Parts list of work able.....	41
7-3 Parts list of step milling head(part A).....	43
7-4 Parts list of 16 steps speed/variable speed milling head(part B).....	45
7-5 Parts list of variable speed milling head(part A).....	47
7-6 Parts list of variable speed milling head(part B).....	49
7-7 Parts list of inverter milling head.....	51
7-8 Parts list of lubrication system.....	54

Chapter 1: INTRODUCTION

1.1 Front View of Machine

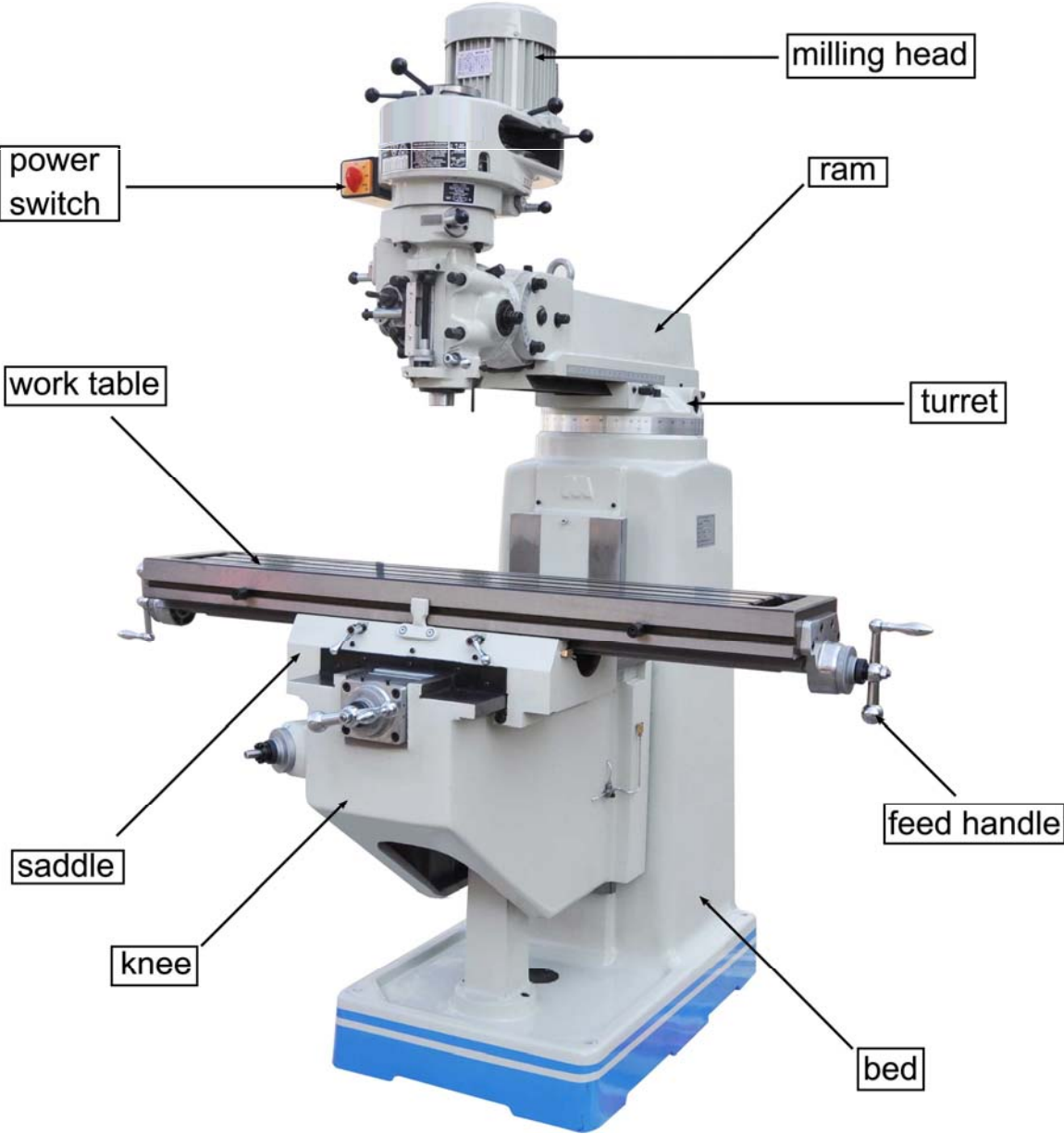

1.2 Machine Main Data Sheet

Model	unit	X6323A	X6323B	X6325	X6325A	X6325B
Table size	mm	230×1067 (9×42") 230×1246 (9×49")		254×1270 (10×50") 254×1370 (10×54")		
T-slot		16mm×3				
Longitudinal travel	mm	650 (840)		850(950)		
Cross travel	mm	305		400		
Vertical travel	mm	400		420		
Ram travel	mm	312		470		
Distance from spindle nose to table surface	mm	0~415		0~405		
Spindle taper		R8 (optional NT30, NT30)				
Quill travel	mm	127				
Spindle speed	r/min	Standard 16 steps: 65-4500 (50HZ); 80-5440 (60HZ) Optional variable speed: 65~4500.				
Quill auto. feed	mm/rev.	0.04 / 0.08 / 0.15				
Spindle motor	Hp	3				
Headstock swivel		±90°				
Headstock tilting		±45°				
Floor space	mm	2200×1600×2000		2550×2200×2240		
Machine weight	Kg	1100	1160	1380	1420	1550

Model	unit	X6325C	X6325D	X6330	X6330A	X6333
Table size	mm	254×1270 (10×50") 254×1370 (10×54")		305×1370 (12×54") 305×1500 (12×60")		30×1370 (12×54") 305×1500 (12×60")
T-slot		16mm×3				
Longitudinal travel	mm	850 (950)		870(1000)		840(1000)
Cross travel	mm	420		380		368
Vertical travel	mm	420		430		450
Ram travel	mm	470		500		
Distance from spindle nose to table surface	mm	0~405		0~350		0~450
Spindle taper		NT40				
Quill travel	mm	127				
Spindle speed	r/min	Standard 16 steps: 65-4500 (50HZ); 80-5440 (60HZ) Optional variable speed: 65~3750.				
Quill auto. feed	mm/re v	0.04 / 0.08 / 0.15				
Spindle motor	Hp	5				
Headstock swivel		±90°				
Headstock tilting		-	±45°	±45°	-	±45°
Floor space	mm	2550×2200×2240		2600×2200×2300		2600×2500×2300
Machine weight	Kg	1590	1590	1700	1750	2300

Chapter 2: SAFETY

For Your Own Safety, Read Instruction Manual Before Operating This Machine!

The purpose of safety symbols is to attract your attention to possible hazardous conditions. This manual uses a series of symbols and signal words intended to convey the level of importance of the safety messages. The progression of symbols is described below. Remember that safety messages by themselves do not eliminate danger and are not a substitute for proper accident prevention measures. Always use common sense and good judgment.



Indicates an imminently hazardous situation which, if not avoided, **WILL** result in death or serious injury.



Indicates a potentially hazardous situation which, if not avoided, **COULD** result in death or serious injury.



Indicates a potentially hazardous situation which, if not avoided, **MAY** result in minor or moderate injury. It may also be used to alert against unsafe practices.

NOTICE

This symbol is used to alert the user to useful information about proper operation of the machine.

2.1 Safety Instruction For Machine



OWNER'S MANUAL:

Read and understand this owner's manual **BEFORE** using machine.

TRAINED OPERATORS ONLY:

Untrained operators have a higher risk of being hurt or killed. Only allow trained/supervised people to use this machine. When machine is not being used, disconnect power, remove switch

keys, or lock-out machine to prevent unauthorized use—especially around children. Make workshop kid proof!

DANGEROUS ENVIRONMENTS:

Do not use machinery in areas that are wet, cluttered, or have poor lighting. Operating machinery in these areas greatly increases the risk of accidents and injury.

MENTAL ALERTNESS REQUIRED:

Full mental alertness is required for safe operation of machinery. Never operate under the influence of drugs or alcohol, when tired, or when distracted.

ELECTRICAL EQUIPMENT INJURY RISKS:

You can be shocked, burned, or killed by touching live electrical components or improperly grounded machinery. To reduce this risk, only allow qualified service personnel to do electrical installation or repair work, and always disconnect power before accessing or exposing electrical equipment.

DISCONNECT POWER FIRST:

Always disconnect machine from power supply BEFORE making adjustments, changing tooling, or servicing machine. This prevents an injury risk from unintended startup or contact with live electrical components.

EYE PROTECTION:

Always wear ANSI-approved safety glasses or a face shield when operating or observing machinery to reduce the risk of eye injury or blindness from flying particles. Everyday eyeglasses are NOT approved safety glasses

WEARING PROPER APPAREL:

Do not wear clothing, apparel or jewelry that can become entangled in moving parts. Always tie back or cover long hair. Wear nonslip footwear to reduce risk of slipping and losing control or accidentally contacting cutting tool or moving parts.

HAZARDOUS DUST:

Dust created by machinery operations may cause cancer, birth defects, or long-term respiratory damage. Be aware of dust hazards associated with each workpiece material. Always wear a NIOSH-approved respirator to reduce your risk.

HEARING PROTECTION:

Always wear hearing protection when operating or observing loud machinery. Extended exposure to this noise without hearing protection can cause permanent hearing loss.

REMOVE ADJUSTING TOOLS:

Tools left on machinery can become dangerous projectiles upon startup. Never leave chuck keys, wrenches, or any other tools on machine. Always verify removal before starting!

USE CORRECT TOOL FOR THE JOB:

Only use this tool for its intended purpose—do not force it or an attachment to do a job for which it was not designed. Never make unapproved modifications—modifying tool or using it differently than intended may result in malfunction or mechanical failure that can lead to personal injury or death!

AWKWARD POSITIONS:

Keep proper footing and balance at all times when operating machine. Do not overreach! Avoid awkward hand positions that make workpiece control difficult or increase the risk of accidental injury.

CHILDREN & BYSTANDERS:

Keep children and bystanders at a safe distance from the work area. Stop using machine if they become a distraction.

GUARDS & COVERS:

Guards and covers reduce accidental contact with moving parts or flying debris. Make sure they are properly installed, undamaged, and working correctly BEFORE operating machine.

FORCING MACHINERY:

Do not force machine. It will do the job safer and better at the rate for which it was designed.

NEVER STAND ON MACHINE:

Serious injury may occur if machine is tipped or if the cutting tool is unintentionally contacted.

STABLE MACHINE:

Unexpected movement during operation greatly increases risk of injury or loss of control. Before starting, verify machine is stable and mobile base (if used) is locked.

USE RECOMMENDED ACCESSORIES:

Consult this owner's manual or the manufacturer for recommended accessories. Using improper accessories will increase the risk of serious injury.

UNATTENDED OPERATION:

To reduce the risk of accidental injury, turn machine OFF and ensure all moving parts completely stop before walking away. Never leave machine running while unattended.

MAINTAIN WITH CARE:

Follow all maintenance instructions and lubrication schedules to keep machine in good working condition. A machine that is improperly maintained could malfunction, leading to serious personal injury or death.

DAMAGED PARTS:

Regularly inspect machine for damaged, loose, or misadjusted parts—or any condition that could affect safe operation. Immediately repair/replace BEFORE operating machine. For your own safety, DO NOT operate machine with damaged parts!

MAINTAIN POWER CORDS:

When disconnecting cord-connected machines from power, grab and pull the plug—NOT the cord. Pulling the cord may damage the wires inside. Do not handle cord/plug with wet hands. Avoid cord damage by keeping it away from heated surfaces, high traffic areas, harsh chemicals, and wet/damp locations.

2.2 Important Safety Information of The Machine

WARNING

Application of the milling machine

The milling machine is designed and constructed for the cutting of metal and similar materials. The machine is along with all the necessary safety requirements. Only fully trained & fully qualified operators should be allowed to operate this machine.

Prohibition:

Untrained operators are prohibited from using this machine.
Modifications that change the function or specification of this machine is prohibited.
Operation of this machine before reading through this instruction manual, is prohibited.

Airborne noise level:

The airborne noise level during operation is about 70~75Db (A).

lighting:

Appropriate lighting must be provided, according to local regulation.

Minimum lighting for this machine is 300 LUX, if there are no any local other local regulations.

Environment:

Ambient air temperature :+5°C~+55°C in free air, and the average ambient air temperature over a period of 24 hours shall not exceed +50°C.

Humidity: 30%~95%.

Altitude: elevation of about 1000m.

Transportation & storage condition: -25°C~+55°C, and for short periods not exceeding 24 hours up to +70°C

2.3 Safety Rules During And /Or Before Operation

WARNING

- Be sure the instruction manual are fully understood.
- Use safety protective equipment such as safety shoes, goggles, clothes, etc.
- Work table near the machine must be strong enough to prevent accidents and be sure articles will never slip off the table surface to interfere with the act of machining.
- Tools and any unnecessary items are not allowed to be placed on the machine table, moving parts, or similar locations.
- Before operating switches , always check if the switches are the right ones and never touch a switch accidentally or it may cause malfunctions or danger.
- Do not operate switches with gloves on. This could cause malfunctions or even danger.
- Do not touch switches with wet hands, an electric shock could occur.
- Warm up the machine before use, especially the spindle and feeding axes by running them for 10 to 20 minutes. It is very important for maintaining machine accuracy.
- If job is to be done by two or more operators, the function of each must be well known, what action will be done and what danger may occur, before the next step is taken.
- Tools should conform to the machine 's specifications, such as dimensions, weight and types.
- Grip workpieces securely to minimize movement or vibration between workpiece and cutting tool or it may injure personnel ,or damage the machine or workpiece.
- Never touch tool nose and cutting chips with bare hands.
- Never try to touch a turning workpiece or spindle in any way.
- Stop the machine before replacing a workpiece and provide plenty of distance between workpiece and tool to avoid impact between workpiece and tool during the changeover.
- In the event of power failure, turn off the main circuit breaker immediately.

- After power failure or an emergency stop, it is necessary to return to reference point of the three axes.
- Do not change electrical settings unless necessary. If such changes are unavoidable , record the original values so that they can be returned to their original settings if needed.
- Before replacing a fuse or electric part , turn off the machine and keep a record of them, for future reference.
- If unspecified lubricant is used , it may result in malfunctions or damage to the machine.
- Limit switches, proximity switches, interlock mechanisms including functional parts and other safety devices should not be removed or modified.
- Dispose of filter material and possible working fluid according to the local regulation.
- Please keep the instruction manual near the machine or in a position easy to be reached by the operator, and keep them for available & in good condition for use.
- Please always quote the machine model and serial number in order for us to deal with any request, as quickly as possible.
- The machine surface is smeared with anti-rust protection when delivered. It should be carefully cleaned & then smeared with protection oil.

2.4 Safety Rules During Electrical Connection Or Disconnection

WARNING

Electrical connection:

- A cable with three wires is supplied to connect your machine into 3 phase power supply.
- The exact power source voltage, frequency, and number of phase shall be checked according to the installation diagram and circuit diagram.
- The correct directions of spindle should be checked after connecting.

Electrical disconnection:

- The disconnection is carried out by hand-operated disconnecting device, which is on the door of control box as an option or connected before the power source.
- Be sure to disconnect this machine from power source, when you want to stop the job for maintenance or adjustment.

Grounding:

- The grounding of this model is carried out by connecting the yellow/green terminal of supply cable to the grounding terminal of power source. Be sure to ground your machine before

connecting machine to power source in any situation.

⚠ WARNING DO NOT DISCONNECT GROUNDING TERMINAL BEFORE DISCONNECTING POWER SOURCE

- Where a portion of the machine and its associated equipment is changed or modified, must be approved by the manufacturer first, and following retest shall be carried out in accordance with the clauses of en60204-1,1992 edition:

Continuity of the protective bonding circuit.(SUBCLAUSE 20.2)

Insulation resistance tests.(SUBCLAUSE 20.3)

Voltage tests. (SUBCLAUSE 20.4)

Functional tests.

Chapter 3: INSTALLATION

3.1 Safety Precautions

CAUTION

- Be sure the instruction manual is fully understood. Must follow instruction manual to operate machine carefully.
- The operator without training or being authorized is prohibited to operate this machine.
- Set all covers in position before operation.
- Use safety protective equipment such as safety shoes, goggles, clothes, etc. and do not wear gloves or ornaments.
- Must not touch running cutters.
- Never try to touch workpiece or clean chips while cutters is running.
- Keep head & hands clear from running machine parts.
- Turn power off before maintenance.

3.2 Unpacking and Cleaning

Your machine was carefully packaged for safe transportation. Remove the packaging materials from around your machine and inspect it. If you discover any damage, please call the sales person immediately.

Save the containers and all packing materials for possible inspection by the carrier or its agent. Otherwise, filing a freight claim can be difficult.

The unpainted surfaces of your machine are coated with a heavy-duty rust preventative that prevents corrosion during shipment and storage. This rust preventative works extremely well, but it will take a little time to clean. Be patient and do a thorough job cleaning your machine. The time you spend doing this now will give you a better appreciation for the proper care of your machine's unpainted surfaces.

There are many ways to remove this rust preventative, but the following steps work well in a wide variety of situations. Always follow the manufacturer's instructions with any cleaning product you use and make sure you work in a well-ventilated area to minimize exposure to toxic fumes.

Before cleaning, gather the following:

- Disposable rags
- Cleaner/degreaser

- Safety glasses & disposable gloves
- Plastic paint scraper (optional)

Basic steps for removing rust preventative:

1. Put on safety glasses.
2. Coat the rust preventative with a liberal amount of cleaner/degreaser, then let it soak for 5–10 minutes.
3. Wipe off the surfaces. If your cleaner/degreaser is effective, the rust preventative will wipe off easily. If you have a plastic paint scraper, scrape off as much as you can first, then wipe off the rest with the rag.
4. Repeat Steps 2–3 as necessary until clean, then coat all unpainted surfaces with a quality metal protectant to prevent rust.

	<p>! WARNING Gasoline and petroleum products have low flash points and can explode or cause fire if used to clean machinery. Avoid using these products to clean machinery.</p>
--	--

	<p>! CAUTION Many cleaning solvents are toxic if inhaled. Only work in a well-ventilated area.</p>
---	---

<p>NOTICE Avoid chlorine-based solvents, such as acetone or brake parts cleaner, that may damage painted surfaces.</p>

3.3 Checking Standard Accessories

The following is a list of items shipped with your machine. Before beginning setup, lay these items out and inventory them. If any non-proprietary parts are missing, please call the sales person immediately for repair.

<p>NOTICE</p> <p>If you can not find an item on this list, carefully check around/inside the machine and packaging materials. Often, these items get lost in packaging materials while unpacking or they are preinstalled at the factory.</p>
--



1. draw bar
2. Hand wheel for quill manual feed
3. Handle for table feed
4. Crank handle for Knee elevating
5. Pulley guard of milling head(only for step speed milling head)
6. Three ball handle for table feed
7. Lever for quill manual feed
8. Wrench
9. Hex. Wrench
10. Screw driver
11. Oil bottle
12. toolbox

3.4 Machine Dimension

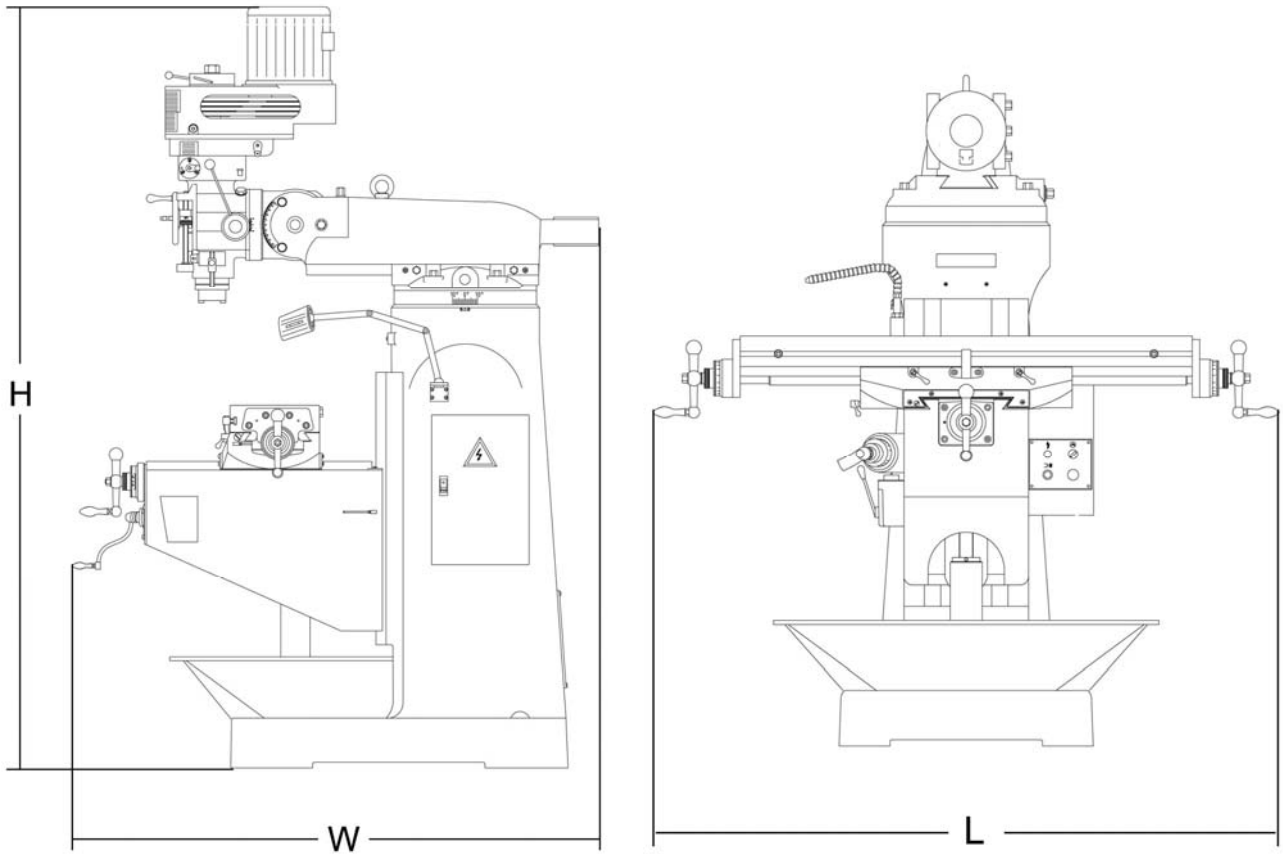

UNIT: mm

	X6323 series		X6325 series		X6330 series		X6333 series	
L	9×42	9×49	10×50	10×54	12×54	12×60	12×54	12×60
	2000	2400	2400	2600	2600	2800	3000	3300
W	1600		2160		2160		2160	
H	2010		2300		2300		2300	

3.5 Foundation

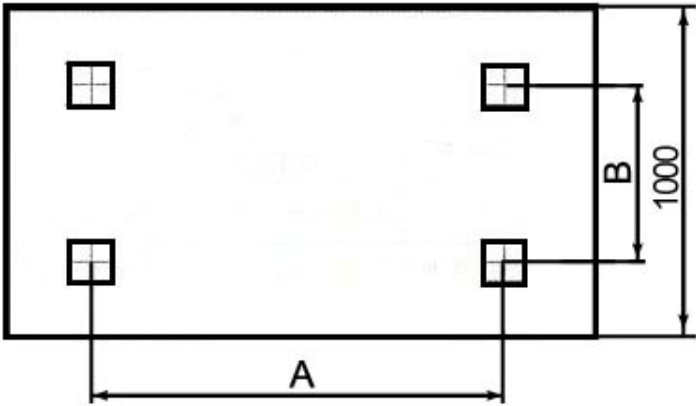
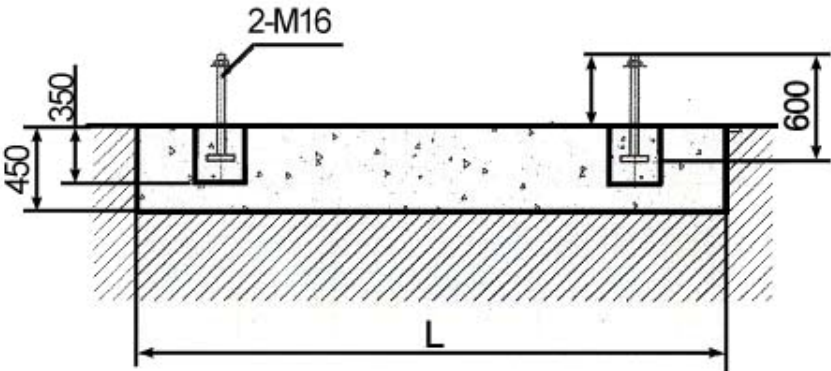

	X6323 Series	X6325 series	X6330 series	X6333 series
L	1500	1500	1600	1600
A	740	889	960	960
B	520	540	540	540

3.6 Lift and Placing

lift and move the machine

1. Remove the coat with the machine, move to installation location.
2. Rotate ram 180° so headstock is facing backwards, then rotate head upright.

Refer to Positioning Head on [Page 27](#) and Positioning Ram on [Page 19](#) for detailed instructions to help with this step.

3. Move the work table near to the column.

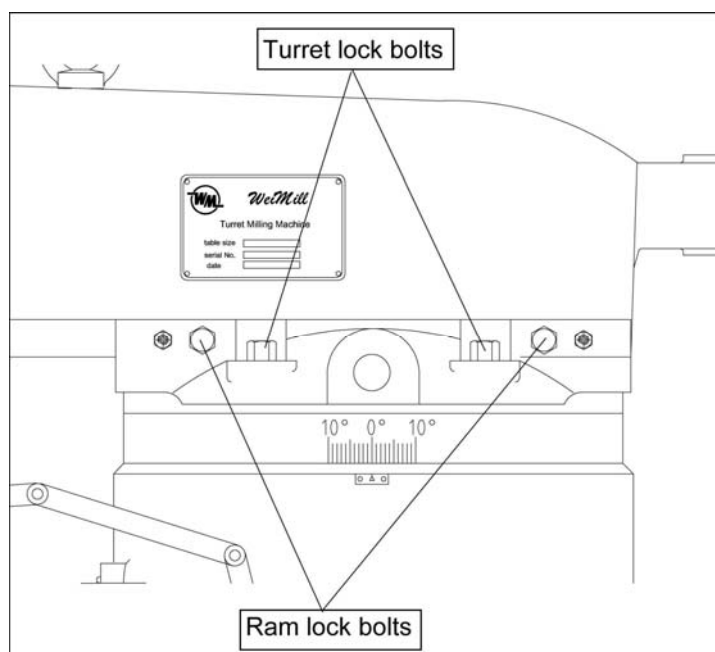
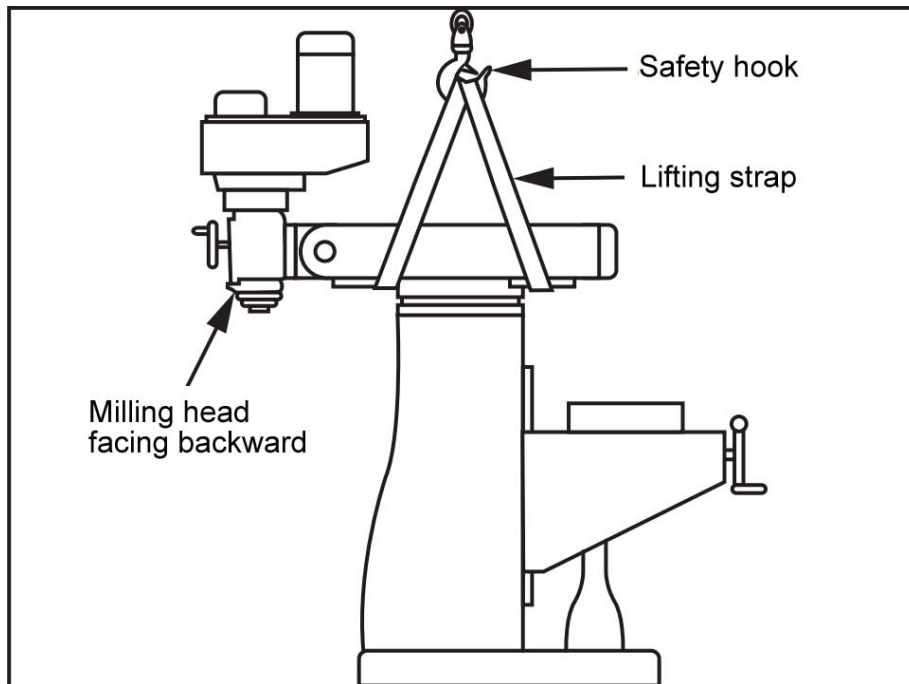

Note: After re-positioning ram and headstock, make sure they are locked in place to prevent unexpected movement during lifting. Make sure the four turret lock bolts (two on each side of the ram, are tighten, to keep the ram from unexpectedly moving from the force of the lifting straps.

4. Place lifting straps under ram and connect them to safety hook

Note: Place protective material between straps and mill to protect ram and ways, and to keep from cutting lifting straps.

5. Unbolt mill from pallet.

If the machine tips to one side, lower it to the floor and adjust ram or table to balance the load.

Make sure to re-tighten lock levers and bolts before lifting mill again.

If the machine lifts evenly, remove pallet and lower mill onto its prepared location.

3.7 Power Supply

⚠️WARNING

The electrical operation must be done by qualified Electrical engineer!

1. Check and confirm correct voltage from factory power source.
2. Turn machine main power switch "OFF", connect machine power cable and ground wire to factory power source.
3. Make machine power on and check spindle motor and coolant pump rotating direction, if rotating direction reverse, switch each two cables connecting terminal to correct it.

NOTICE

make sure the spindle and coolant pump motor work on correct rotating direction.

3.8 Align the Milling Head

The milling head have been turned down against the work table before delivery. So the head must be turned up and re-align again.

1. Align R/L direction

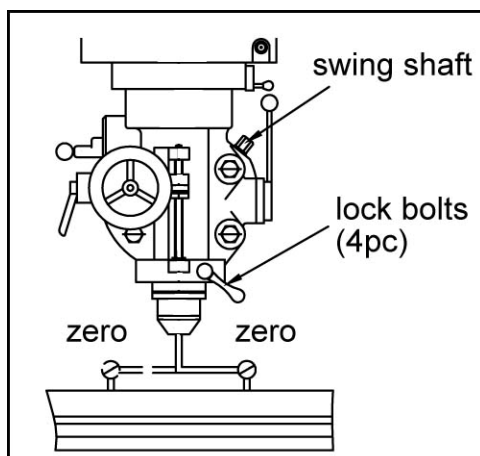

Loosen 4 sets of lock bolts behind of the milling head.

Set an indicator with 100mm arm in the spindle.

Turn the swing shaft and make the milling head rotate to set the milling head square to table surface at right and left direction.

And then tighten the 4 lock bolts again.

The head is heavy. When tilting or rotating head, get help to support its weight as you make adjustments.

Note: The lock bolts are threaded into T-nuts that travel in a circular slot during head rotation. When rotating head, it is possible for these T-nuts to jam in the slot preventing movement of head. If this happens, gently rotate each lock bolt, starting with the lower right, until you free up the jammed T-nut. Then continue to rotate head to desired position.

2. Align B/F direction

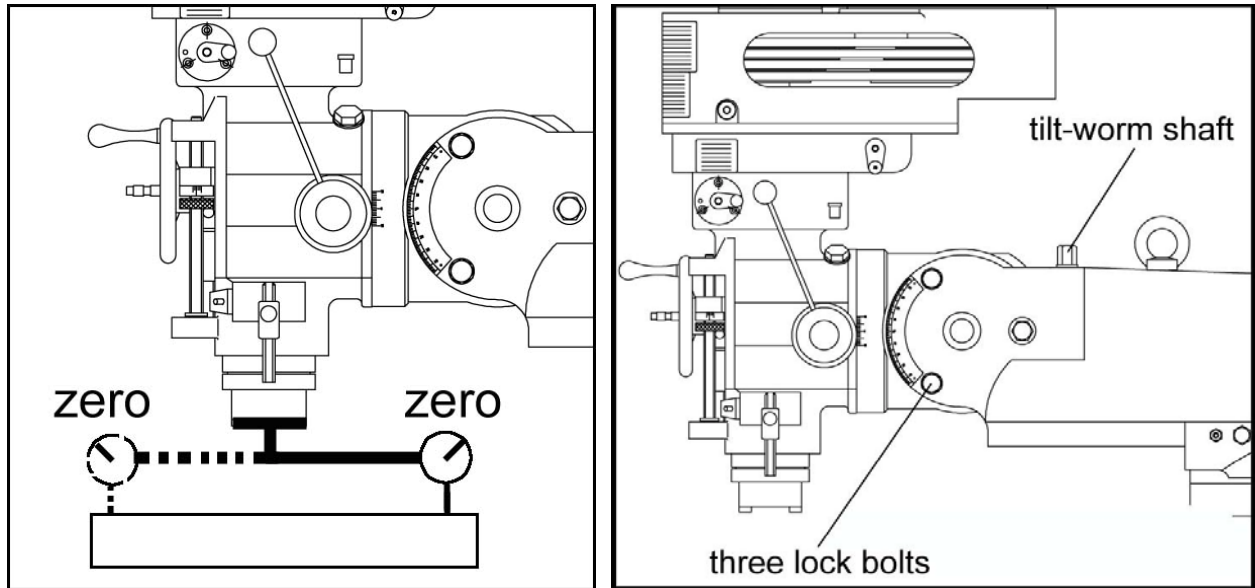

Loosen 3 sets of lock bolts beside of the ram.

Set an indicator with 100mm arm in the spindle.

Turn the tilt-worm shaft and make the milling head rotate up or down, to set the milling head square to table surface at backward and forward.

And then tighten the 3 sets lock bolts again.

Chapter 4: OPERATIONS

4.1 Positioning The Ram

The ram can rotate 360° around the turret, and move forward or backward.

Rotating the ram

1. DISCONNECT MACHINE FROM POWER!
2. Loosen four lock bolts on top of turret.

Note: There are two lock bolts on each side of the ram.

NOTICE In the next step, take care not to entangle or stretch electrical cabling as you move ram around turret.

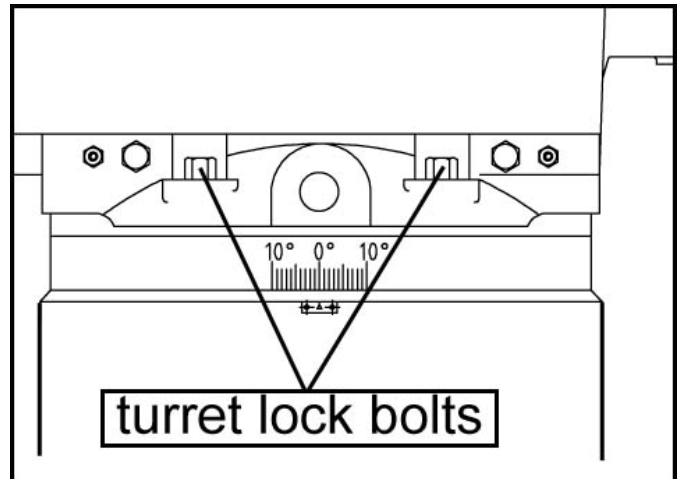

3. Push head to manually rotate ram. Use rotation scale to determine correct position for your operation, then re-tighten four lock bolts to secure ram in place.

Move Ram Backward/Forward

1. DISCONNECT MACHINE FROM POWER!
2. Loosen two lock bolts.
3. Make sure there are no obstructions to ram travel, especially any tooling around workpiece, then slowly rotate gear shaft to move ram. Rotate bolt clockwise to move ram away from table and counterclockwise to move ram toward table.
4. Re-tighten lock bolts.

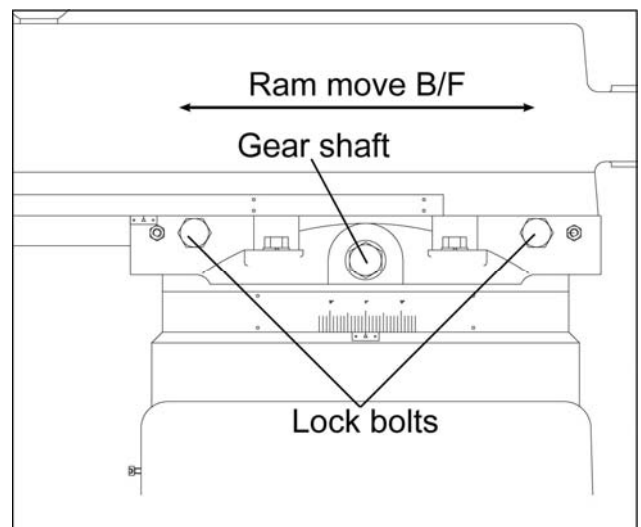

4.2 Locking the Table, Saddle, and Knee

- While processing, the work table, saddle and knee need to be locked for good rigidity.
- Locking the work table
the lock levers are located on front of the work table. And turn the lever clockwise to tighten the table and anticlockwise to loosen.

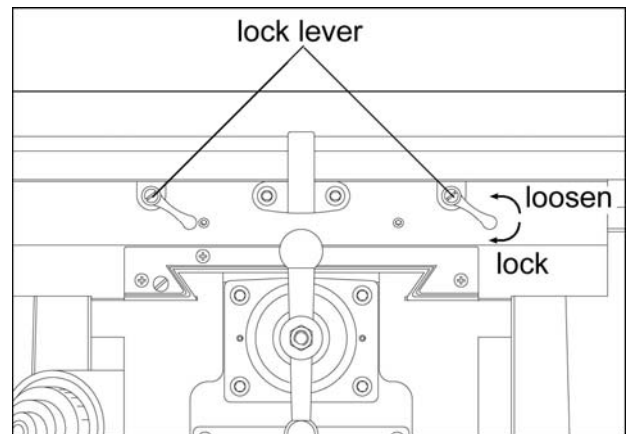

- Locking the saddle
the saddle lock levers are located on left side of saddle. And turn the lever clockwise to tighten the saddle and anticlockwise to loosen.

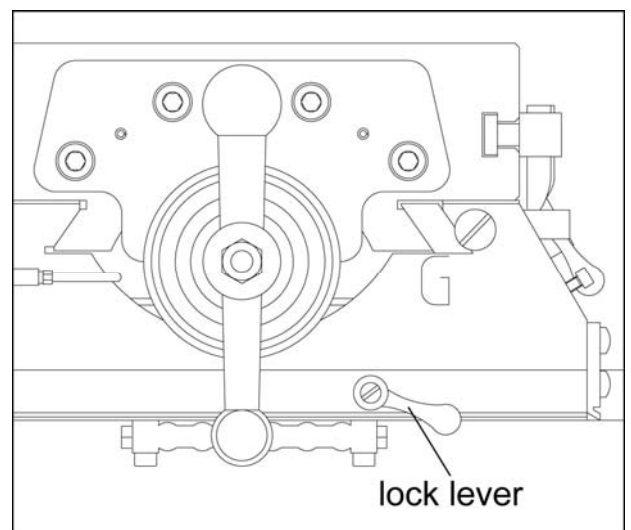

- Locking the Knee
the knee lock levers are located on left side of the Knee. And turn lever clockwise to tighten the saddle and anticlockwise to loosen.

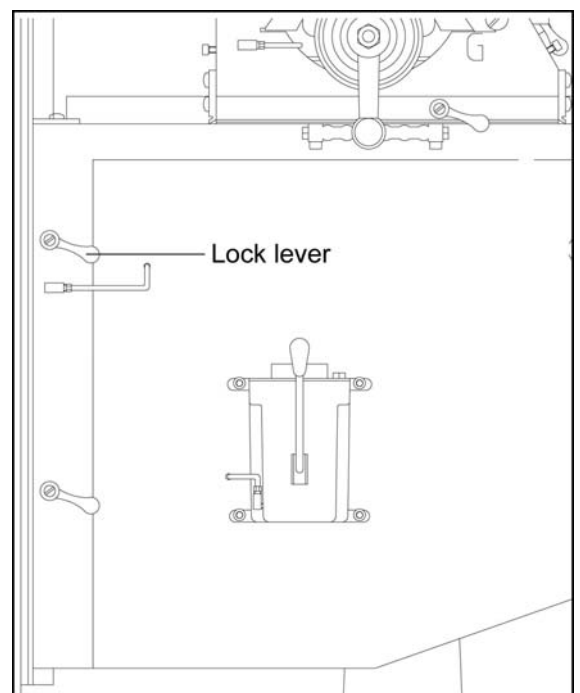

Chapter 5: OPERATIONS OF MILLING HEAD

5.1 Operating Levers instruction

Step Speed Milling Head

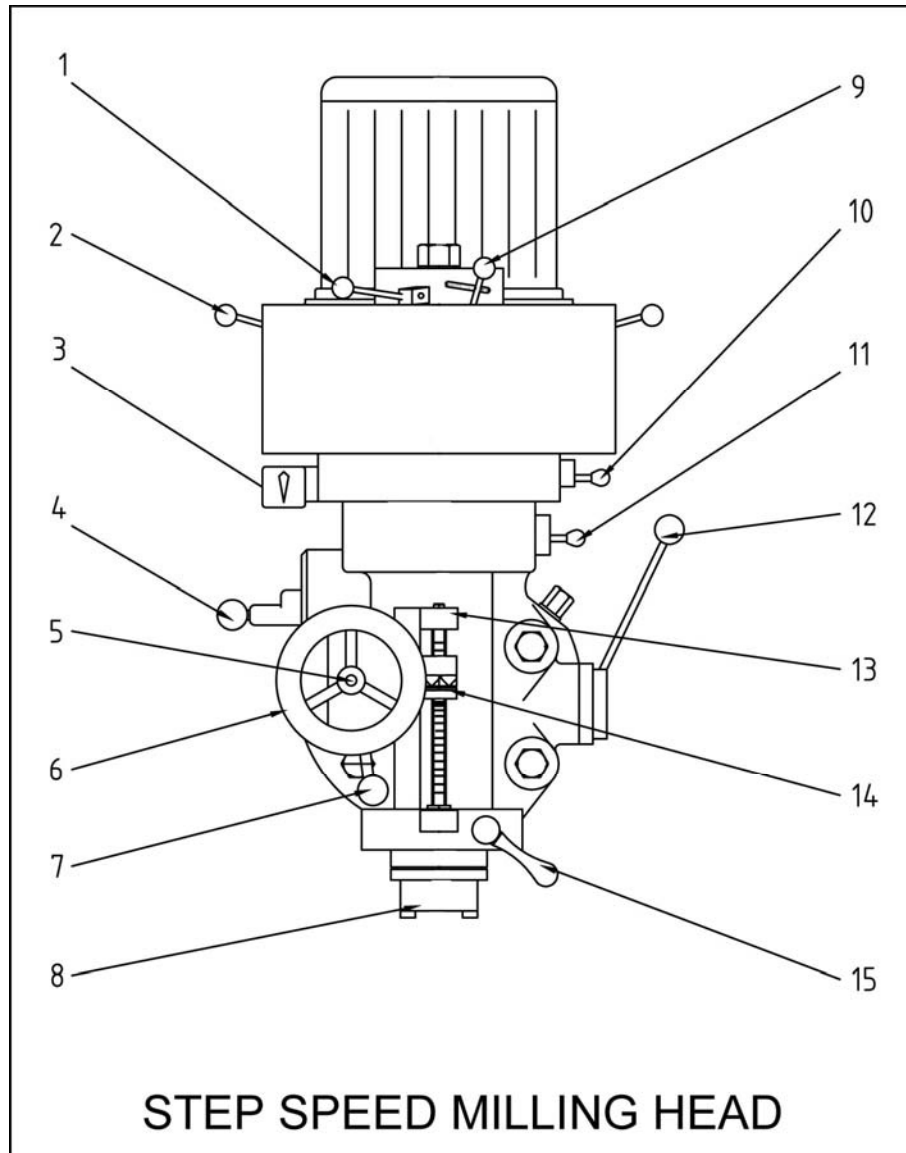

No.	Name	Function	No.	Name	Function
1	Spindle brake handle	Make the spindle fast stop	5	Feed reverse Knob	Pull it out or push in to control quill feed direction
2	Motor lock handle	lock/loosen motor	6	Fine feed handwheel	Realize fine manual feed by the wheel
3	Power switch	Power on/off, control spindle H/L speed and direction	7	Auto. feed engage lever	Pull the lever out, auto. feed engaged, push it in, auto. feed will stop.
4	Feed rate control lever	Set quill auto feed rate	8	Spindle	R8 / NT30 / NT40

No.	Name	Function	No.	Name	Function
9	H/L speed clutch	Cooperate with No.10 lever to realize spindle H/L speed change	13	Quill feed dog	While the dog touch the adjust. Nut, quill auto. feed stop.
10	H/L speed control lever	Cooperate with clutch to realize spindle H/L speed change	14	Quill feed adjust. nut	Rotate it to set quill feed depth, and while dog touch it the auto. feed stop
11	Auto quill feed engage	Make the quill auto feed gear set engage or disjoint	15	Quill clamping lever	Tighten the quill
12	Quill feed handle	Turn the handle to make quill manual down feed			

Variable Speed Milling Head

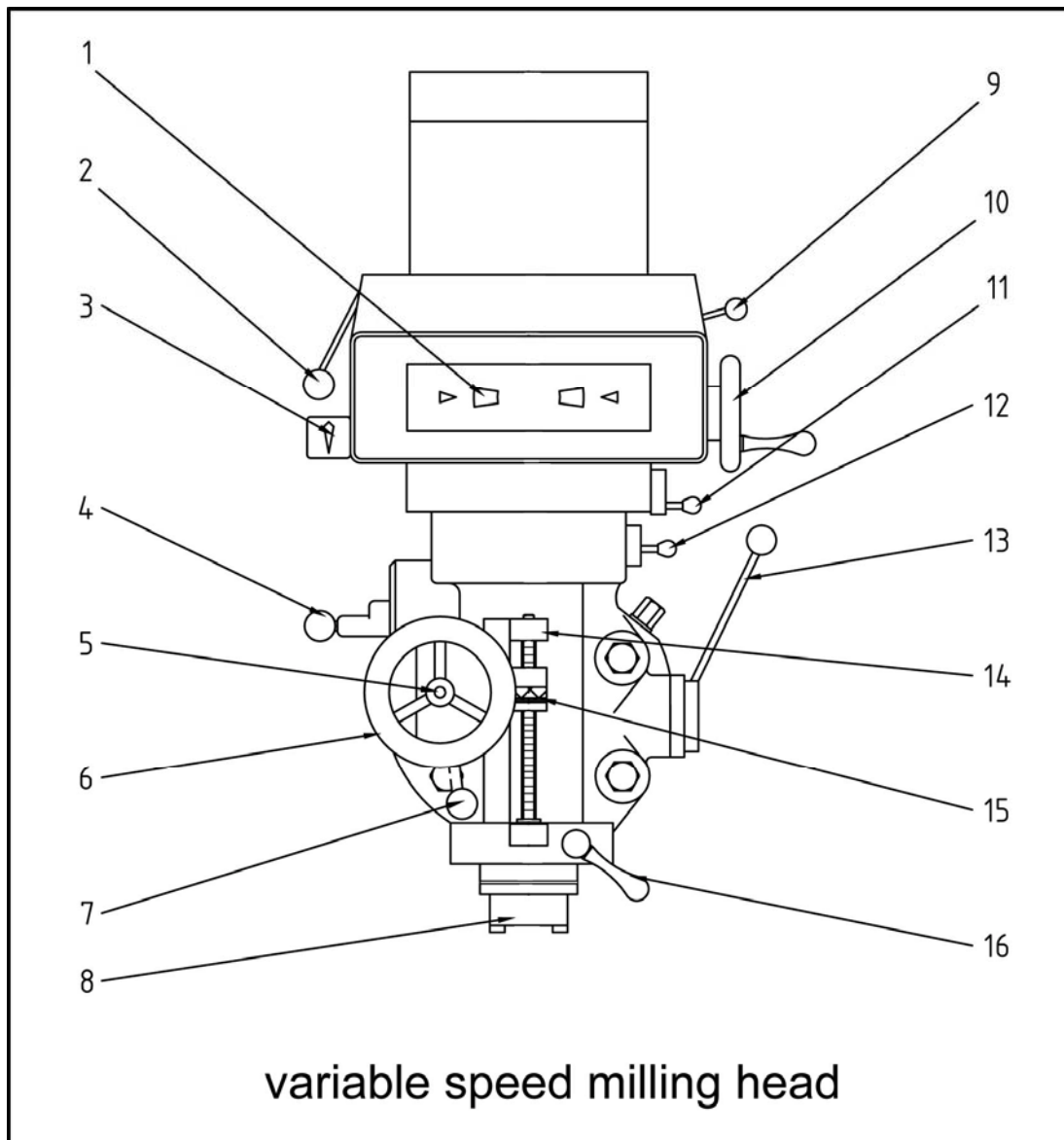

No.	Name	Function	No.	Name	Function
1	Spindle speed indicator	Show the speed of spindle	9	Motor lock handle	lock/loosen motor
2	Spindle brake handle	Make the spindle fast stop	10	Speed select wheel	Rotate the wheel to change spindle speed
3	Power switch	Power on/off, control spindle rotate direction	11	H/L speed control lever	Cooperate with clutch to realize spindle H/L speed change
4	Feed rate control lever	Set quill auto feed rate	12	Auto quill feed engage	Make the quill auto feed gear set engage or disjoint
5	Feed reverse Knob	Pull it out or push in to control quill feed direction	13	Quill feed handle	Turn the handle to make quill manual down feed
6	Fine feed handwheel	Realize fine manual feed by the wheel	14	Quill feed dog	While the dog touch the adjust. Nut, quill auto. feed stop.
7	Auto. feed engage lever	Pull the lever out, auto. feed engaged, push it in, auto. feed will stop.	15	Quill feed adjust. nut	Rotate it to set quill feed depth, and while dog touch it the auto. feed stop
8	Spindle	R8 / NT30 / NT40	16	Quill clamping lever	Tighten the quill

5.2 Spindle Speed Selecting

Step Speed Milling Head

For the step speed milling head, spindle with 16 steps speed. The different speed be set by 1. Motor power switch which with high/low speed control; 2, position of V-belt.

To set spindle speed:

1. DISCONNECT MACHINE FROM POWER! And make sure the spindle is stop.
2. Use chart below or spindle speed chart on headstock to find appropriate spindle speed for your operation
3. Pull H/L speed control lever out, position in HIGH or LOW range, then release lever to seat

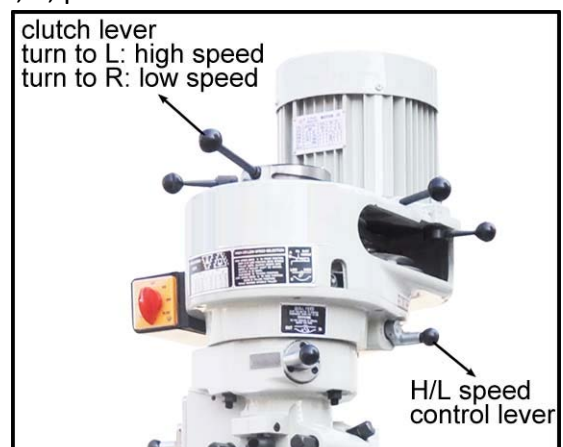

knob pin in detent.

Note: If it is difficult to move range selector knob, rotate spindle by hand to help mesh gears until selector moves freely.

- Turn Clutch lever to HIGH or LOW speed position

Note: Firmly grasp spindle, then quickly rotate it back and forth until you hear/feel front pulley drop into spindle clutch. If this step was not successful, repeat this step until you are certain that spindle is seated into spindle clutch.

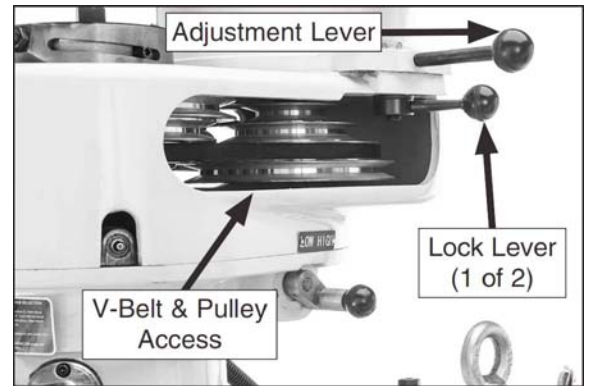

- Remove belt housing side covers on either side of head to expose V-belt and pulleys. Loosen two motor lock levers, one on each side of head, then pull belt tension adjustment lever forward to release V-belt tension
- Refer to spindle speed chart on front of headstock and position V-belt on pulleys for desired spindle speed.
- Push adjustment lever backward with moderate force to re-tension V-belt, then re-tighten two lock levers to secure motor
- Replace two belt housing side covers before re-connecting mill to power.

Step spindle speed chart:

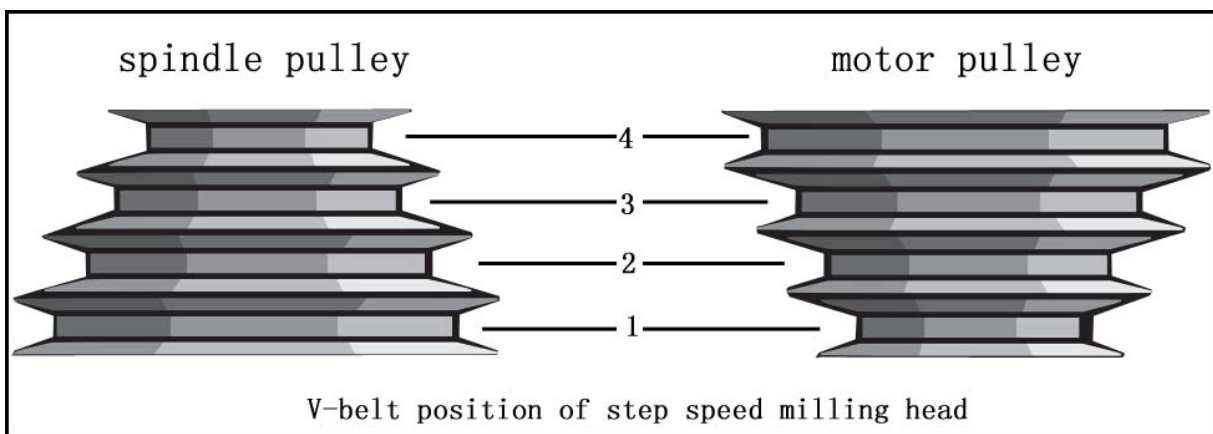

(Note: the speeds are base on 50HZ, corresponding speed on 60hz list in bracket)

v-belt positon	Motor on H speed		Motor on Low speed	
	H	L	H	L
1	1100 (1320)	132 (160)	550 (660)	66 (80)
2	1860 (2220)	220 (270)	930 (1110)	110 (135)

3	2920 (3500)	350 (420)	1460 (17500)	175 (210)
4	4540 (5440)	540 (650)	2270 (2720)	270 (525)

Variable Speed Milling Head

1. Make sure spindle is completely stopped, then use chart below to find spindle speed range that includes required spindle speed for your operation
2. Pull H/L speed control lever out, move to HIGH or LOW position, then release lever to seat lever pin in detent.
Note: If it is difficult to rotate lever, rotate spindle by hand to help mesh gears until selector moves freely.

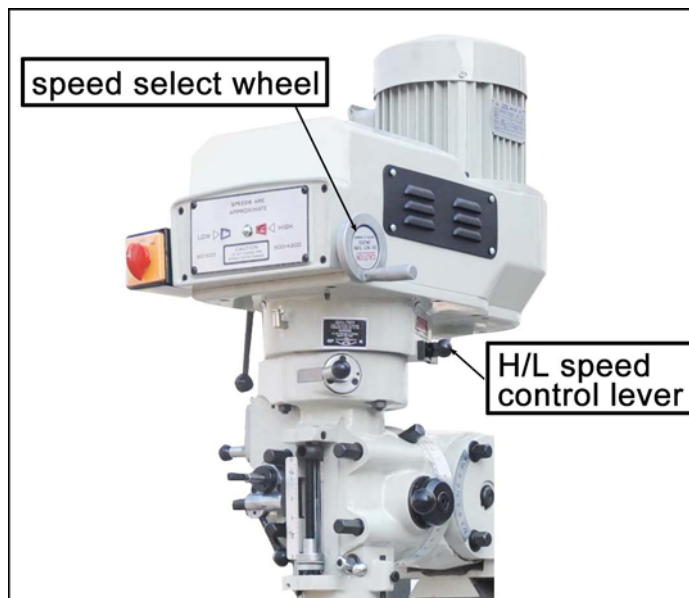

3. Use spindle switch to start spindle rotation.
4. Slowly rotate speed select wheel, until desired speed is displayed in indicator for speed range selected.

Variable speed range:

	H SPEED	L SPEED
50HZ	470~3500	50~410
60HZ	550~4300	60~500

5.3 Spindle Down Feed

Manual feed

The quill can realize manual fine or rough down feed by “ fine feed hand wheel” or quill feed handle”.

Auto. down feed

Auto-Downfeed Rate Selector. Selects one of the three auto down feed rates:

0.04(0.0015 in)/rev, 0.08(0.003 in)/rev, 0.15 (0.006 in)/rev.

Use auto. down steps:

1. Make sure spindle is completely stopped.
2. Pull auto. quill feed engage lever out, then rotate it clockwise until knob pin seats in auto-down -feed (engaged) detent

Note: It may be necessary to turn the spindle by hand as you move the selector to enable the gears to mesh.

3. Position quill feed adju. nut for spindle depth that is correct for your operation, then secure it in place with locking net.
4. Position Feed reverse Knob for spindle travel direction is correct for your operation. If necessary, rock fine downfeed handwheel back-and-forth to move pin all the way in or out.

Note: The direction pin has three positions:

- 1) In for one downfeed direction,
- 2) middle for neutral or no movement,
- 3) out for the reverse direction.

The direction of spindle travel for the in and out positions is relative to the direction of spindle rotation. Keep in mind that spindle rotation and downfeed direction will reverse when the spindle speed range is changed.

5. Make sure auto feed engage lever is all the way to right in disengaged position so that spindle will not travel when rotation is started.

Note: We recommend that you complete the remaining steps without a cutting tool installed, without a workpiece in place, and the table lower than the maximum spindle downfeed travel. This will enable you to test and confirm the settings before beginning the actual cutting operation.

NOTICE To avoid damage to system gearing, never use auto down feed system while spindle speed is over 1700 r/min.

6. Select one of the three downfeed rates by pulling feed rate control lever out, position selector over appropriate detent, then release lever. Make sure pin is firmly seated by attempting to move it without pulling lever out.
7. Use quill manual feed handle to lower spindle slightly until you can pull clutch lever out to the

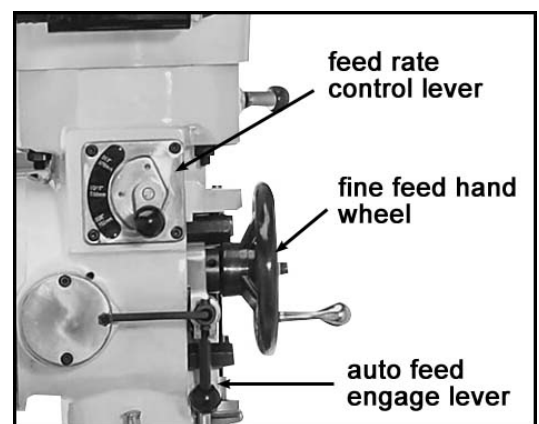
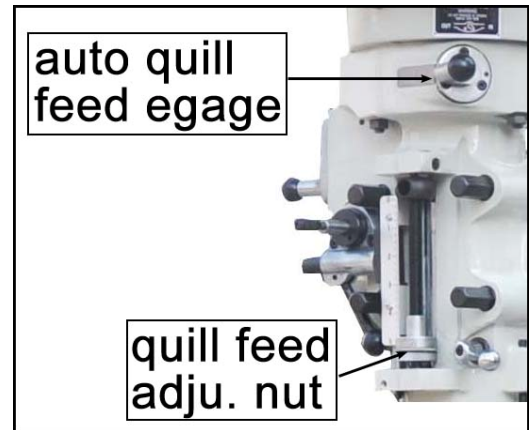

left and it locks in place, which will start auto-down feed spindle travel.

5.4 Swing Milling Head Forward or Backward

1. DISCONNECT MACHINE FROM POWER!
2. Loosen three lock bolts.
3. Use one hand to apply pressure to head in direction of tilt, then slowly rotate tilt-worm shaft.

Note: Rotate tilt-bolt clockwise to tilt head backward and counterclockwise to tilt it forward.

⚠ CAUTION the milling head is heavy. While tilting or rotating head, get help to support its weight as you make adjustments.

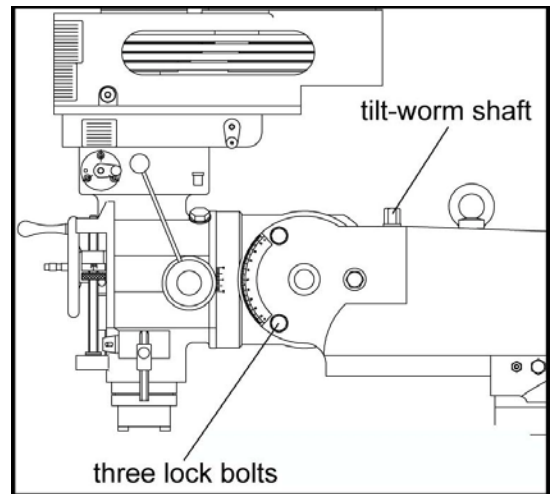

5.5 Swing Milling Head Right or Left

1. DISCONNECT MACHINE FROM POWER!
2. Loosen four lock bolts.
3. Use one hand to apply pressure to head in direction of rotation, then slowly turn swing shaft

Note: Turn rotation bolt clockwise to rotate head left and counterclockwise to rotate it right.

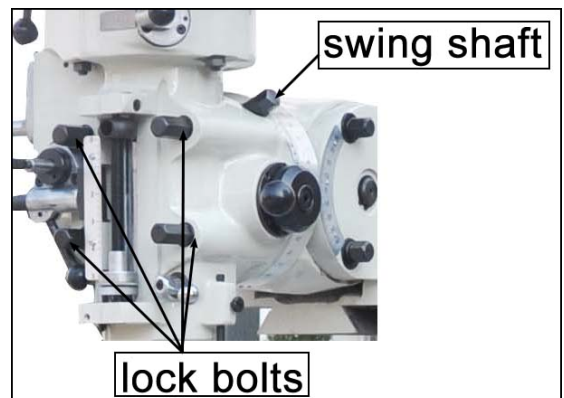

Note: The lock bolts are threaded into T-nuts that travel in a circular slot during head rotation. When rotating head, it is possible for these T-nuts to jam in the slot preventing movement of head. If this happens, gently rotate each lock bolt, starting with the lower right, until you free up the jammed T-nut. Then continue to rotate head to desired position.

Chapter 6: MAINTENANCE

6.1 Adjusting Gibs

Gibs are tapered lengths of metal that are sandwiched between two moving surfaces. Gibs control the gap between these surfaces and how they slide past one another. Correctly adjusting the gibs is critical to producing good milling results.

Tight gibs make table movement more accurate but stiff. Loose gibs make moving the table sloppy but easier to do. The goal of gib adjustment is to remove unnecessary sloppiness without causing the ways to bind.

Gibs are adjusted with a screw on each end of the gib, that move the tapered gib back-and-forth to increase or decrease the friction pressure between the sliding surfaces. The process of properly adjusting the gibs requires trial-and-error and patience.

To adjust Gib

1. DISCONNECT MACHINE FROM POWER!
2. Make sure all table/knee locks are loose.
3. Loosen one gib adjustment screw, then tighten the other the same amount to move the gib.
4. Use ball handles/crank to move table/knee until you feel a slight drag in the path of movement. repeat Steps 3–4 as necessary.

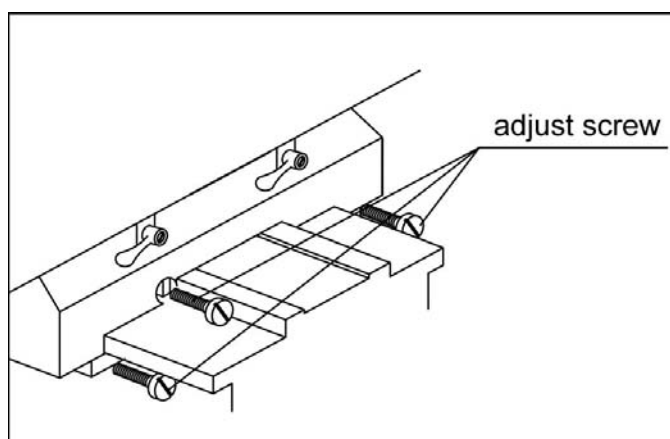
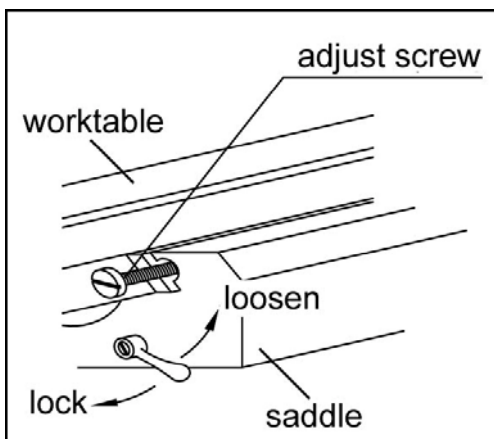
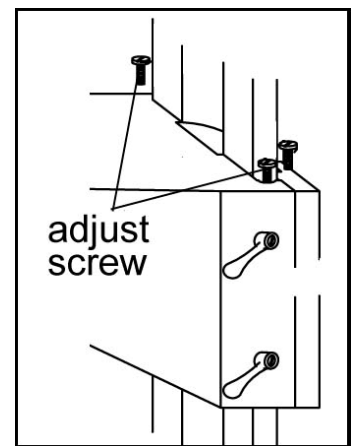

Note: It will be necessary to remove small parts, such as way wipers and covers, to access the gib adjustment screws.

6.2 Adjust Leadscrew Backlash

Leadscrew backlash is the amount of motion or "play" in leadscrew rotation before the attached device begins to move. Leadscrews will always have a certain amount of backlash that will increase with normal wear.

Generally, 0.1~0.2mm leadscrew backlash is acceptable to ensure smooth movement and reduce the risk of premature thread wear. However, if you find it necessary to adjust leadscrew backlash, perform the procedures listed below.

● Adjust Table Lead Screw Backlash

Leadscrew of worktable longitudinal feed is located under the work table, which with two nuts. One is fixed, and another one with ring slot is adjustable

1. DISCONNECT MILL FROM POWER!
2. Move the table to right side and make the leadscrew nut exposed.
3. Loosen lock screws on leadscrew nut accessed from underneath left side of table.
4. Rotate adjustable nut on clockwise in small increments, then check amount of backlash.

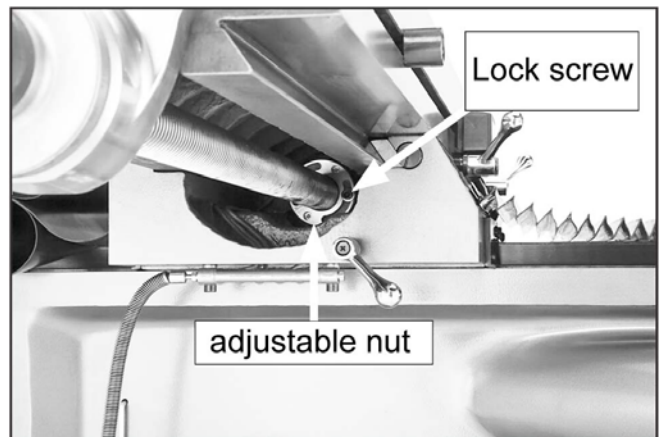

5. When you are satisfied with adjustment, retighten lock screw screws.

● Adjust Cross Lead Screw Backlash

1. DISCONNECT MACHINE FROM POWER!
2. Move the saddle to front as far as possible.
3. Remove hex nut and ball handle from cross leadscrew.

Note: In the next step, take care not to misplace the leadscrew key as you remove the parts.

4. Unthread and remove knurled retaining ring, graduated dial ring, and leadscrew key.



5. Remove four screws from bearing housing, then slide it off leadscrew.
Note: It may be necessary to use a dead blow hammer or rubber mallet on the housing to knock it loose.
6. Loosen the lock screw for tighten the adjustable lead nut.
7. Re-install key back onto leadscrew so that you can use ball handle in next step.
8. Rotate adjustable leadscrew nut in small increments, slide ball handle onto leadscrew, then check amount of backlash.
9. When you are satisfied with adjustment, retighten two lock screws.
10. Re-install parts previously removed in reverse order.

6.3 Lubrication

The machine has numerous moving metal-to-metal contacts that require regular and proper lubrication to ensure efficient and long-lasting operation, and to protect your investment.

Other than the lubrication points covered in this section, all other bearings are internally lubricated and sealed at the factory. Simply leave them alone unless they need to be replaced.

Before performing any lubrication task, DISCONNECT MACHINE FROM POWER!

Important: Before adding lubricant, clean the debris and grime from the oil cup or grease fitting and the immediate area to prevent contamination of the new lubricant.

Use the schedule and information in Figure as a daily guide for lubrication tasks. Follow the referenced sections on the following pages for detailed instructions.

NOTICE

The following recommended lubrication schedule is based on light to medium mill usage.

Keeping in mind that lubrication helps to protect value and operation of mill, you may need to perform lubrication tasks more frequently depending on your usage.

Lubrication point	Frequency (hours of operation)
Slide way	4~8 Hrs
Ram way	40 Hrs
Knee elevating leadscrew	40Hrs
Quill	4 Hrs
Quill gear	4~8 Hrs
Headstock gear	40 Hrs

1. Slide Way Lubrication

Oil Type: Model SB1365 or ISO 68 Equivalent Oil.

Amount: One Pull of Pump Handle

Check/Add Frequency: 4–8 Hrs. of Operation

The one-shot oil pump is connected to a series of aluminum tubes that carry the lubricant to wear points on slide ways, cross and longitudinal feed screws.

Pull the handle out slowly then release it to send the oil through the tubes then move the table through all paths of movement to evenly distribute the lubricant.

Use the sight glass on the side of the oiler to know when to re-fill the reservoir. The oil tank capacity is about 0.5L.



2. Milling Head Quill Lubrication

Oil Type: Model SB1365 or ISO 68 Equivalent Oil.

Amount: Oil cup

Check/Add Frequency: 4–8 Hrs. of Operation

Lift oil cup cap and add 5~10 drops of lubricant.

3. Milling Head Quill Gear Lubrication(only for Variable speed milling head)

Oil Type: Model SB1365 or ISO 68 Equivalent Oil.

Amount: Oil cup

Check/Add Frequency: 4–8 Hrs. of Operation

Lift oil cup cap and add 5~10 drops of lubricant.



4. Milling Head up Gearbox Lubrication(only for Variable speed milling head)

Grease Type: NLGI #2 or Equivalent.

Amount: two pumps of Grease gun

Check/Add Frequency: 40 Hrs. of Operation

Add two pumps by a grease gun.



5. Rack of Ram slide way

Grease Type: ISO68 or Equivalent.

Amount: Thin coat

Check/Add Frequency: 40 Hrs. of Operation

Move the ram back and forth as necessary to access the full travel of the slide ways. Then use a clean brush to apply a thin coat of lubricant to the ways and racks.

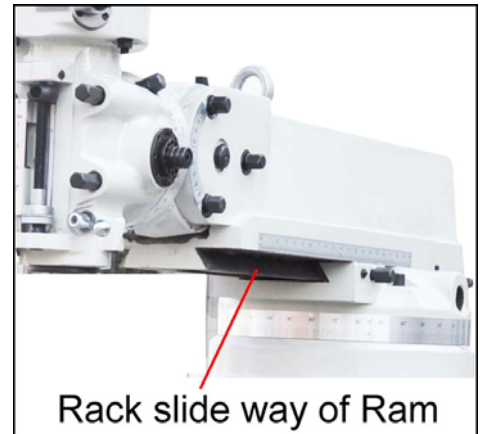

6. Elevating lead screw lubrication

Grease Type: NLGI #2 or Equivalent

Grease Amount: Thin Coat

Check/Add Frequency: 40 Hrs. of Operation

Elevate the table all the way up, then use mineral spirits to clean any debris and built-up grime from the elevation leadscrew threads. Add one pump from a grease gun to the leadscrew grease fitting, then run the Knee up and down to distribute the grease. Repeat this process until the entire leadscrew is well lubricated.

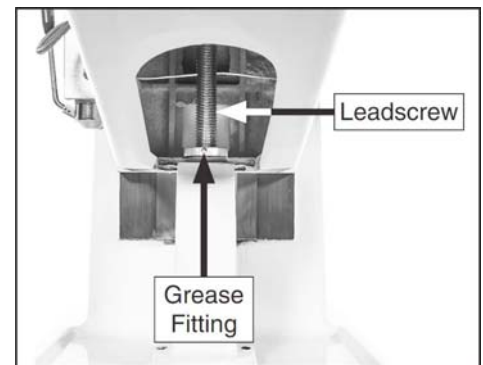

6.4 Quill reverse Spring Replacement

1. Move quill up to end position, and dismantle manual feed hand base.
2. Remove the bracket with 12 holes.
3. Rotate spring holder on anticlockwise to release spring tension.
4. Remove the spring out of the holder.
5. Refit new spring into the holder, and test spring reverse tension as required.
6. Then assemble these parts again.

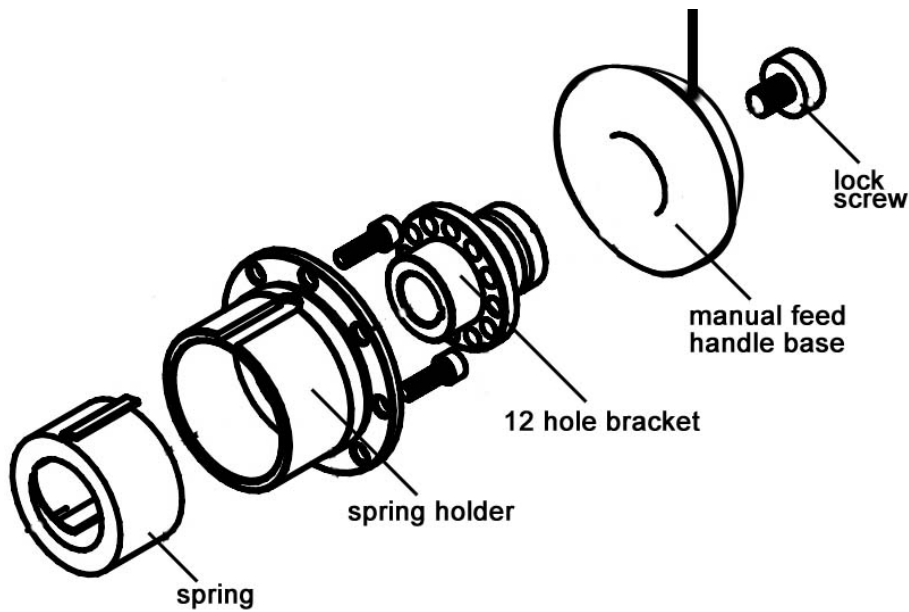

6.5 Replace motor, belt and brake assy. of variable speed milling head

1. Running spindle and set it on high speed.
2. DISCONNECT MACHINE POWER!
3. Remove drawbar
4. Remove rear cover of head stock
5. Remove motor mount screws, then remove motor (tilting the motor to forward and pull up)
6. Remove headstock side cover and drive belt, and replacing a new drive belt. And then

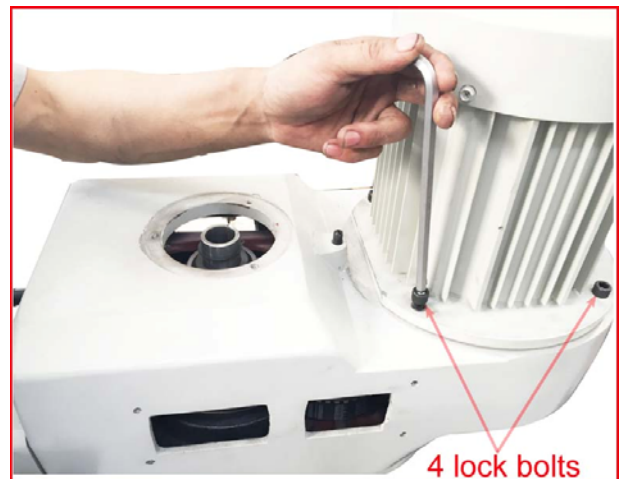

reinstall dismantled parts again.



If replacing timing belt or brake assembly, proceed to Step following:

7. Remove top cover of head stock.



8. Loosen speed change disk (which connect with speed changing chain). Before

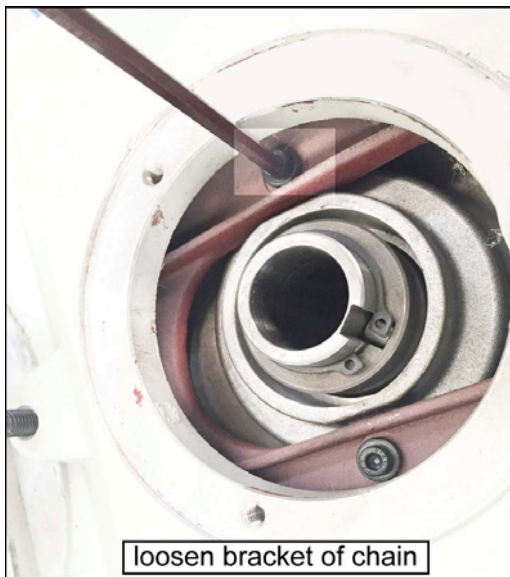

9. Remove the lock bolts for top housing of headstock and rear gear box housing.



10. And then make top housing separate from gear box housing.

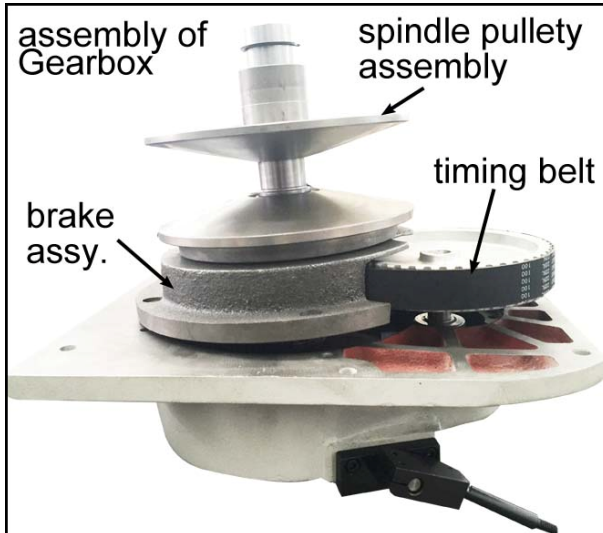

11. Remove all the parts step by step, and replace the timing belt or brake assembly.

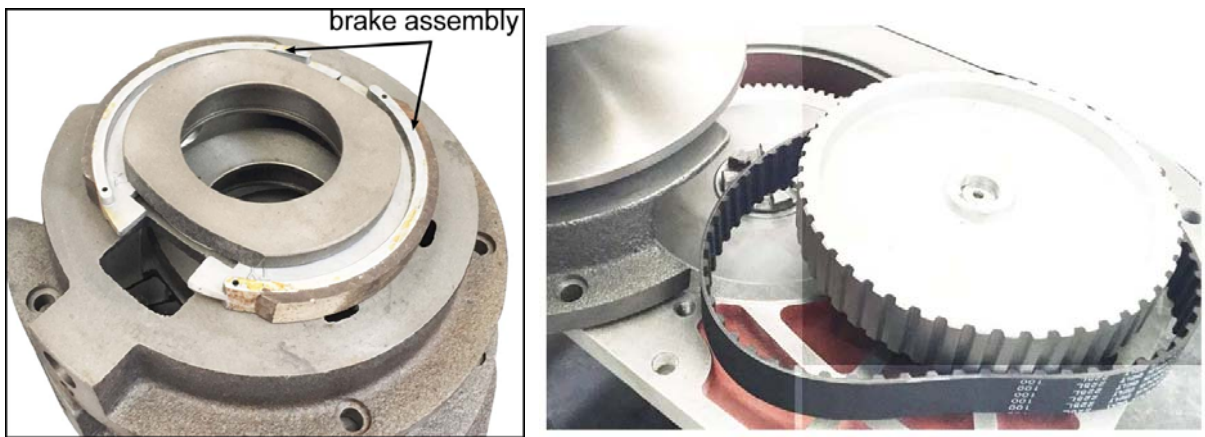

12. Re-assemble milling head in reverse order from steps 3~11.

6.6 Replace motor, belt and brake assy. of step speed milling head

Replacing a broken belt or the spindle brake assembly requires removing the motor and part of the headstock.

Since the procedure for replacing the spindle brake assembly involves removing many of these same components as in a belt replacement, it is a good idea to check the brake assembly whenever you replace a belt, and replace the shoes if necessary.

The steps of replacing belt and brake assembly:

1. DISCONNECT MACHINE FROM POWER!
2. Remove drawbar (see Page 41).
3. Remove motor lock screws, then remove the motor.

Note: If V-belt is not broken, be sure to carefully remove it from motor pulley before lifting motor off of headstock.

4. Remove the clutch on the top of the headstock

5. Remove the lock nuts that secure part A to part B.

Note: the PART A is composed of the belt housing and gear box, which should be separated in next step.

6. Remove the lock screws and separate gear box and belt housing.

7. Replace the bad belts if necessary.

If you want to check and replace brake assembly, go on

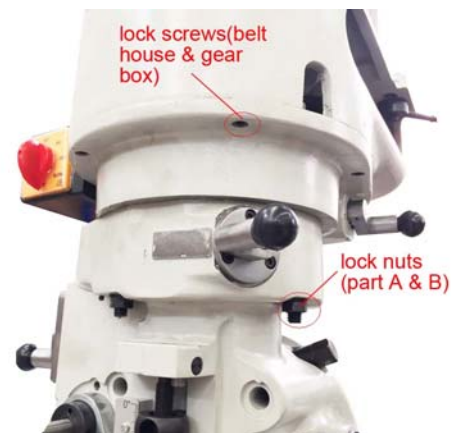
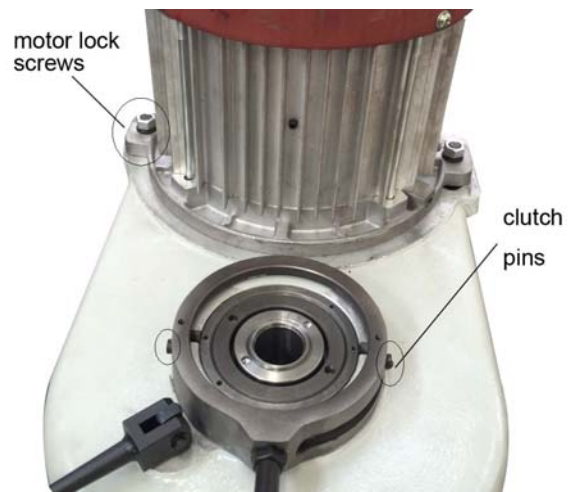

8. Slide motor pulley up to remove it from belt housing, inspect brake assembly for damage or wear, and replace if necessary.

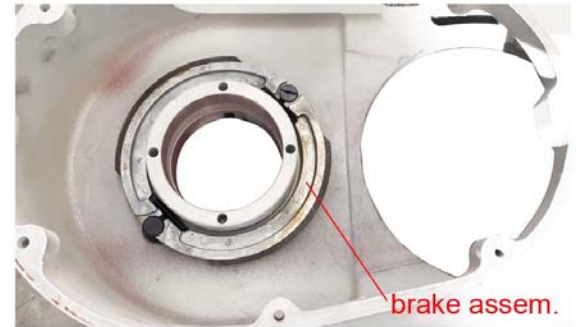

9. Re-assemble milling head in reverse order from Steps 3–8.

Parts No	Name	Parts No	Name
C001	Worm shaft	C052	Screw plug
C002	Sleeve of worm shaft	C053	Work table
C003	Worm	C054	Round head screw
C004	Spring pin	C056	Oil scraper
C005	Ram	C059	Right oil scraper
C008	adapter	C060	Left oil scraper
C009	Worm	C061	Gib of knee
C010	Spring pin	C062	Travel set screw
C011	Hex. Socket screw	C063	Chip guard
C012	Mark	C064	Chip guard
C013	Zero indicator	C065	Chip guard
C014	Rivet	C066	Knee
C015	Spring lock washer	C067	Hex. Socket screw
C016	Lock screw	C068	Side cover plate
C017	Mark	C069	Hex. Socket screw
C018	Bracket	C070	Oil nozzle
C019	Ruler	C071	Elevating nut
C020	Sleeve	C072	Lead screw bracket
C021	Axle of adapter	C073	Hex. Socket screw
C022	Zero indicator	C074	Filter screen
C023	Turret	C075	Front cover
C024	Gib	C076	Hex. Socket screw
C025	Ruler	C077	Hex. Socket screw
C026	Bracket screw	C079	Key
C027	Spring lock washer	C080	Elevating lead screw
C028	Set screw	C081	Hex. Head nut
C029	Lock screw	C083	Washer
C030	Hex. Head screw	C084	Bevel gear
C031	Lock pin	C085	Washer
C032	Lock screw	C086	Bearing
C035	Gear shaft	C087	Bearing shield
C036	Body	C088	Hex. Socket screw
C037	Lock pin	C089	Hex. Socket screw
C038	Lock handle	C092	Pinion bevel gear
C040	Lock pin	C094	Bearing
C041	Travel set handle	C095	Key
C042	Travel set block	C096	Elevating shaft
C043	Nut	C097	Baring bracket
C044	Adjusting screw for gib	C098	Bearing shield
C045	Saddle	C099	Hex. Socket screw
C046	Gib of table	C100	Washer
C047	Lock pin	C101	Dial plate

C048	Gib of saddle	C102	Nut
C050	Travel stop block	C103	Clutch sleeve
C051	Hex. Socket screw	C105	Elevating crank handle
C106	Washer	C108	Handle
C107	Hex. Socket screw		

7.2 Parts list of work table

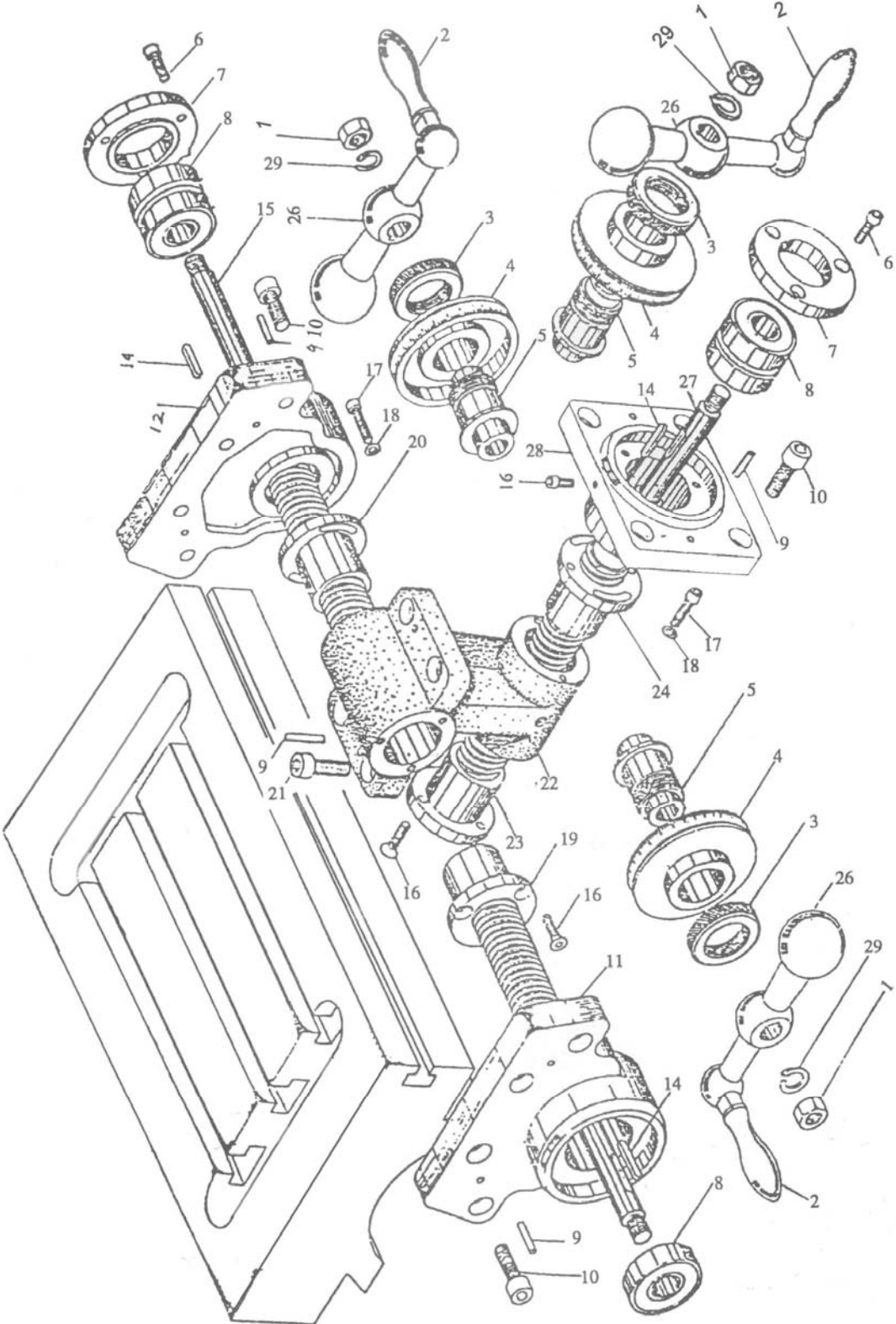

Part No	Parts Name
D001	Hex. Head nut
D002	Handle
D003	Dial plate lock nut
D004	Dial plate
D005	Dial plate holder
D006	Screw
D007	Bearing shield
D008	Bearing
D009	Pin
D010	Screw
D011	Left bearing bracket
D012	Right bearing bracket
D013	Bearing
D014	Key
D015	Longitudinal feed screw
D016	Screw
D017	Screw
D018	Washer
D019	Longitudinal feed nut
D020	Longitudinal feed nut
D021	Screw
D022	Feed nut bracket
D023	Cross lead feed nut
D024	Cross lead feed nut
D026	Crank handle
D027	Cross feed screw
D028	Bearing bracket
D029	Lock washer

7.3 Parts list of 16 steps milling head (PART A)

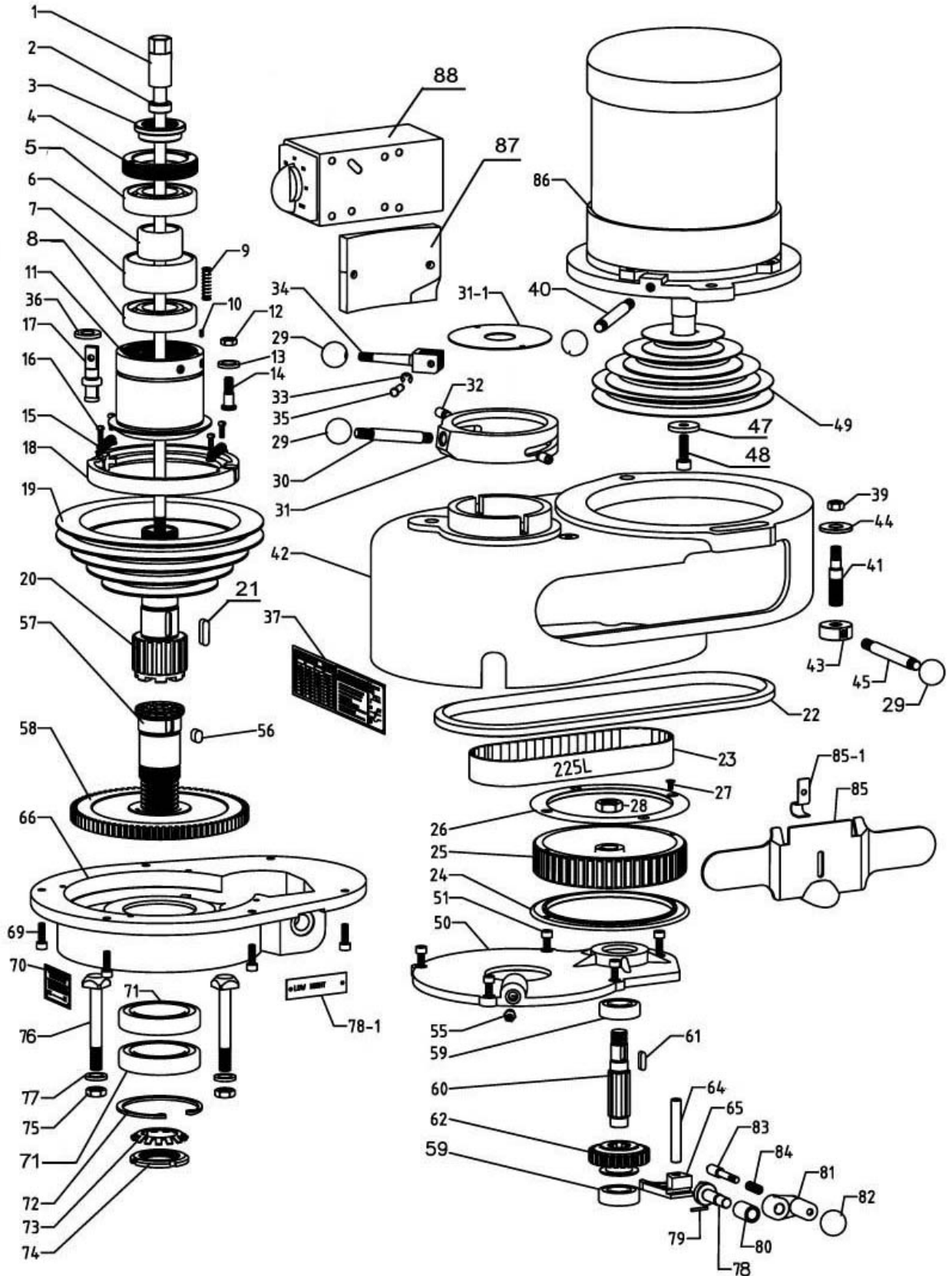

No.	Name	No.	Name	No.	Name
A1	Draw bar	A29	Plastic ball	A62	Small gear
A2	Washer	A30	Clutch lever 5/16	A64	Sliding pin
A3	Locknut	A31	Clutch disk	A65	Gear engaging fork
A4	Sleeve nut	A31-1	Top shield	A66	Back gear box
A5	Bearing 6207	A32	Dowel pin with screw	A69	Screw 6×20
A6	Internal space sleeve	A33	Retaining ring	A70	Power feed mark
A7	External space sleeve	A34	Brake handle	A71	Bearing 6208
A8	Bearing 6207	A35	Pin	A72	retaining ring 80
A9	spring (4pc)	A37	Speed table	A73	Toothed washer 40
A10	Set screw 3×8	A39	Nut 3/8×24	A74	Bearing lock nut
A11	Spindle pulley sleeve	A40	Motor move handle	A75	Nut 7/16
A12	Nut 5/16	A41	Motor lock shaft	A76	T bolt (3pc)
A13	Washer 5/16	A42	Pulley housing	A77	Washer 7/16
A14	Brake lock screw	A43	Motor lock nut	A78	Eccentric shaft
A15	Spring (2pc)	A44	Washer	A79	Pin 3×20
A16	Screw	A45	Handle	A80	Sleeve
A17	Brake shaft	A47	Washer	A81	Gear engaging crank
A18	Brake assembly	A48	Screw	A82	Plastic ball
A19	Spindle pulley	A49	Motor pulley	A83	Alignment pin
A20	Pulley shaft	A50	Back gear box cover	A84	Spring
A21	Key 6×25	A51	Screw 5×12	A85	Side shield
A22	V belt	A55	Oil cup	A85-1	Clip of shield
A23	Timing belt (225L)	A56	Key 8×15	A86	AC Motor
A24	Pulley flange	A57	Spindle gear shaft	A87	Switch bracket
A25	Timing Pulley	A58	Spindle gear	A88	Reversing switch
A26	Pulley flange	A59	Bearing 6203		
A27	Screw	A60	Small gear shaft		
A28	Nut 5/8×18	A61	Key 5×15		

No.	Name	No.	Name	No.	Name
B1	Screw	B40	Cooper worm wheel	B81	Shaft sleeve
B2	Washer	B41	Bearing BA66	B82	Key
B3	Bevel pinion shaft	B42	Copper sleeve	B88	Spring
B5	Bushing	B43	Auto. Feed worm	B89	Bar
B6	Pin	B44	copper sleeve	B90	Bushing
B7	Worm spacer	B47	Thrust washer	B92	Feed worm wheel
B8	Feed worm	B48	Bushing	B93	Teethed clutch ring
B9	Worm shaft	B49	Bevel Pinion	B94	Retaining ring
B11	Key	B50	Clutch	B95	Pin
B12	Screw	B51	Bevel pinion	B96	Feed control lever
B13	Washer	B52	Copper sleeve	B97	Washer
B14	Key	B55	Feed control pull bar	B98	Retaining ring
B15	Reversing gear	B56	Pin $\Phi 3 \times 20$	B99	Clutch plate
B16	Dowel pin	B57	Feed worm shaft	B98	Ring
B17	Worm bracket	B59	Pin $\Phi 3 \times 16$	B99	Clutch plate
B18	Eccentric shaft	B60	Sliding shaft	B100	Setscrew
B19	Shaft housing	B61	Screw	B101	Locknut
B20	Bar	B62	key	B103	Slide shaft
B21	Spring	B63	Feed changing fork	B104	Feed control lever
B22	Pin	B64	Eccentric shaft	B105	Plastic ball
B23	Crank	B66	Clutch plate	B106	Feed trip bracket
B24	Plastic ball	B67	Screw	B107	Screw
B25	Screw	B68	Alignment bar	B108	Screw
B27	Copper sleeve	B69	Spring	B110~112	Pull lever
B28	Multi-gear	B70	Feed change crank	B113	Hand wheel clutch
B29	Key	B71	Pin 3×20	B114	Steel Ball
B31	Multi-gear shaft	B72	Plastic ball	B115	Spring
B32	Retaining ring	B73	Screw	B116	Screw
B33	Copper sleeve	B74	Screw	B118	Slide block
B34	Washer	B75	Copper sleeve	B119	Pin
B35	Reversing gear shaft	B76	Screw	B120	Spring
B36	Feed gear	B77	Brass plug	B121	Stop plunger
B37	Key	B79	Spring	B123	Plunger pushing
B38	Multi-gear shaft	B80	Overload clutch	B124	Push bar

7.5 Parts list of Variable speed milling head (Part A)

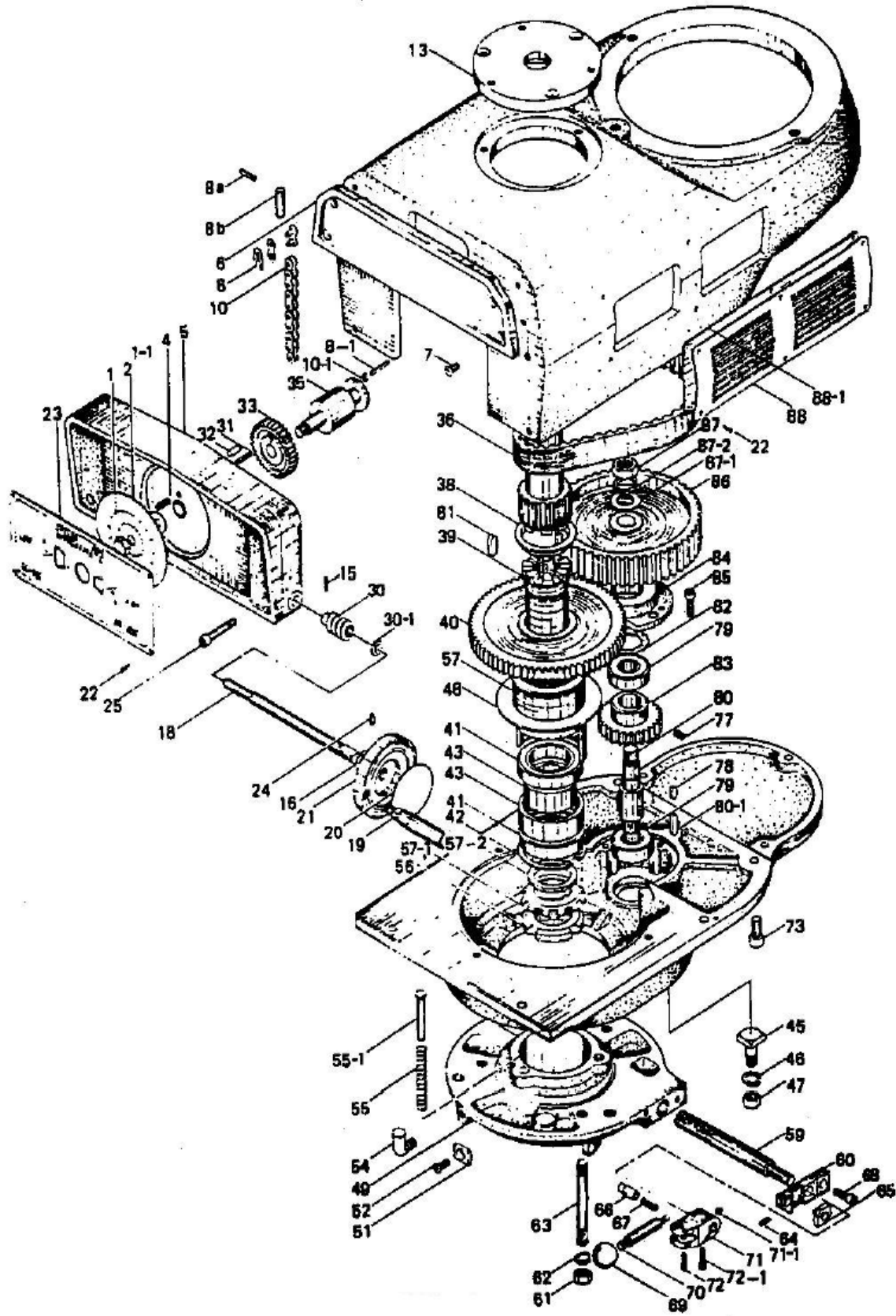

No.	Name	No.	Name
VA 1	Screw	VA 49	Clutch bracket
VA 2	Speed indicator	VA 51	Clutch
VA 3	Copper bearing	VA 52	Screw
VA 4	Set screw	VA 54	Oil cup
VA 5	Bracket	VA 55	Spring
VA 8	Chain	VA 56	Bearing lock nut
VA 8-1	Dowel pin	VA 57	Bearing quill
VA 8-a	Dowel pin	VA 57-2	Washer
VA 8-b	Space	VA 58	Spring ring
VA 8-c	Cotter pin	VA 59	Pinion shaft
VA 10	Speed change chain	VA 60	Brake set
VA 13	Bearing cover	VA 61	Nut
VA 15	Dowel pin	VA 62	Lock washer
VA 16	Spring	VA 63	Bolt
VA 17	Copper bearing	VA 64	Setscrew
VA 18	Speed change shaft	VA 65	Adjusting plate
VA 19	Handle	VA 66	Brake lever
VA 20	Mark brand	VA 67	Spring
VA 21	Speed change wheel	VA 68	Setscrew
VA 22	Screw	VA 69	Handle ball
VA 23	Plate	VA 70	Speed change crank
VA 24	Setscrew	VA 71	Pinion stop block
VA 25	Screw	VA 72	Dowel pin
VA 30	Worm	VA 72-1	Screw
VA 31	Copper bearing	VA 73	Screw
VA 32	Dowel pin	VA 77	Screw
VA 33	Speed change gear	VA 78	Key
VA 35	Wheel	VA 79	Ball bearing
VA 36	Belt	VA 80	Pinion counter shaft
VA 38	Clutch quill	VA 81	Key
VA 39	Spindle gear sleeve	VA 82	Spring ring
VA 40	Spindle gear assembly	VA 83	Pinion
VA 41	Ball bearing	VA 84	Pinion bearing cover
VA 42	Ring	VA 85	Screw
VA 43	Gear bearing space	VA 86	Timing pulley
VA 45	T bolt	VA 87	Locknut
VA 46	Washer	VA 88	Guard
VA 47	Nut	VA 89	Screw
VA 48	Washer		

7.6 Parts list of Variable speed head (Part B)

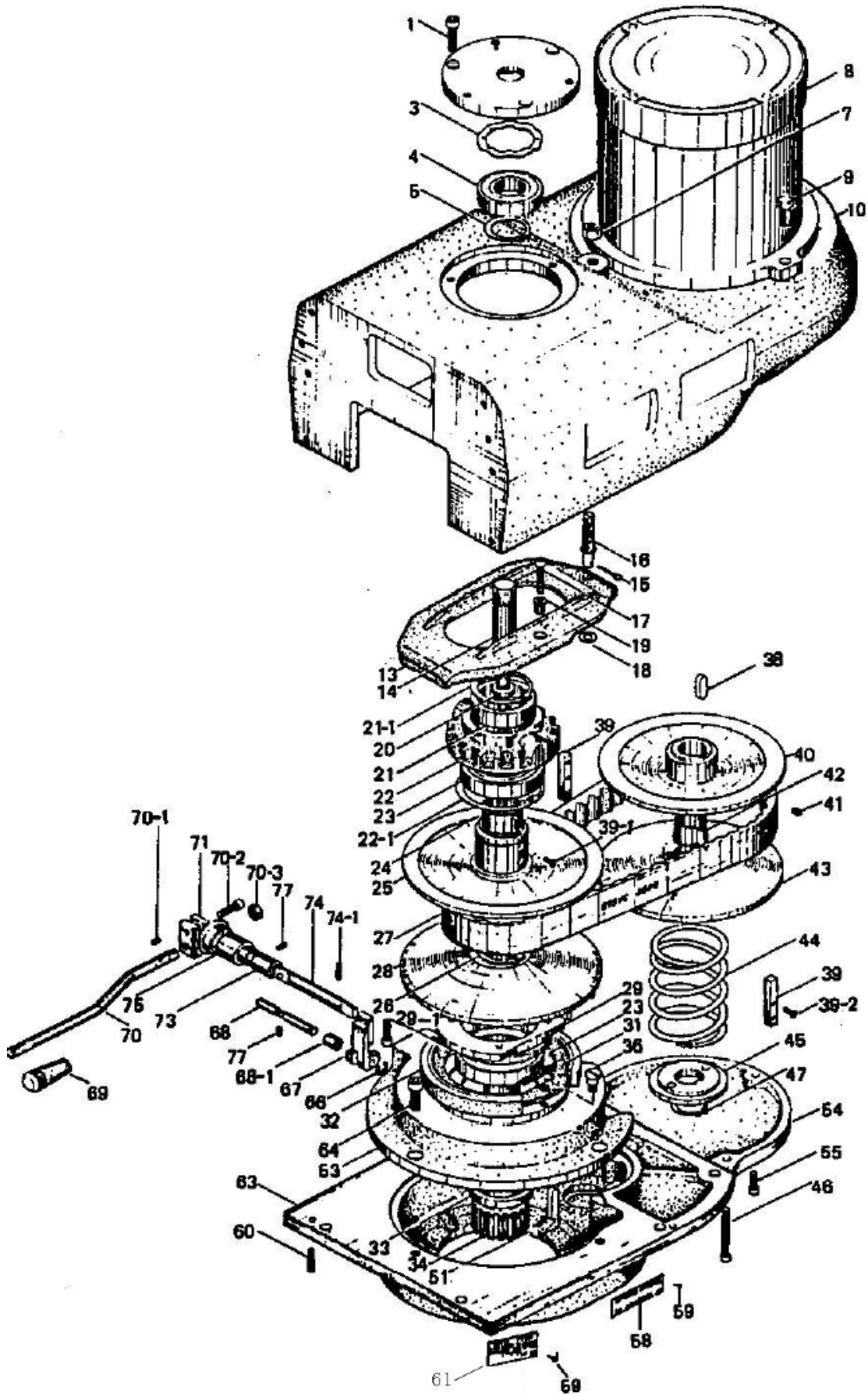

No.	Name	No.	Name
VB 1	Screw	VB 37	Dowel pin
VB 3	Spring washer	VB 38	Key
VB 4	Ball bearing	VB 39	Key
VB 5	Spring ring	VB 40	Fixed speed disk
VB 7	Lock nut	VB 41	Setscrew
VB 8	Motor	VB 42	Copper sleeve
VB 9	Screw	VB 43	Vari. Speed disk assembly
VB H8018	Washer	VB 44	Spring
VB 13	Housing plate	VB 45	Spring house
VB 14	Joint shaft	VB 46	Screw
VB 15	Lock pin	VB 47	Ring
VB 16	Bolt	VB 51	Key
VB 17	Screw	VB 53	Pulley cover plate
VB 18	Washer	VB 54	Motor pulley cover
VB 19	Bolt sleeve	VB 55	Screw
VB 20	Washer	VB 58	Mark
VB 22	Bearing housing	VB 59	Rivet
VB 23	Ball bearing	VB 60	Taper pin
VB 24	Copper sleeve	VB 61	Quill feed mark
VB 25	Vari. Speed disk	VB 63	Gear box cover
VB 26	Ring	VB 64	Screw
VB 27	Belt	VB 66	Ring
VB 28	Fixed disk	VB 67	Needle
VB 29	Brake	VB 68	Shaft
VB 29-1	Screw	VB 69	Ball
VB 31	Brake spring	VB 70	Brake handle
VB 32	Brake assembly	VB 71	Brake lock pin
VB 33	Spindle pulley space	VB 72	Setscrew
VB 34	Spindle pulley	VB 73	Brake shaft sleeve
VB 35	Bolt	VB 74	Brake shaft
VB 36	Brake arbor	VB 77	Screw

7.7 Parts list of Inverter milling head

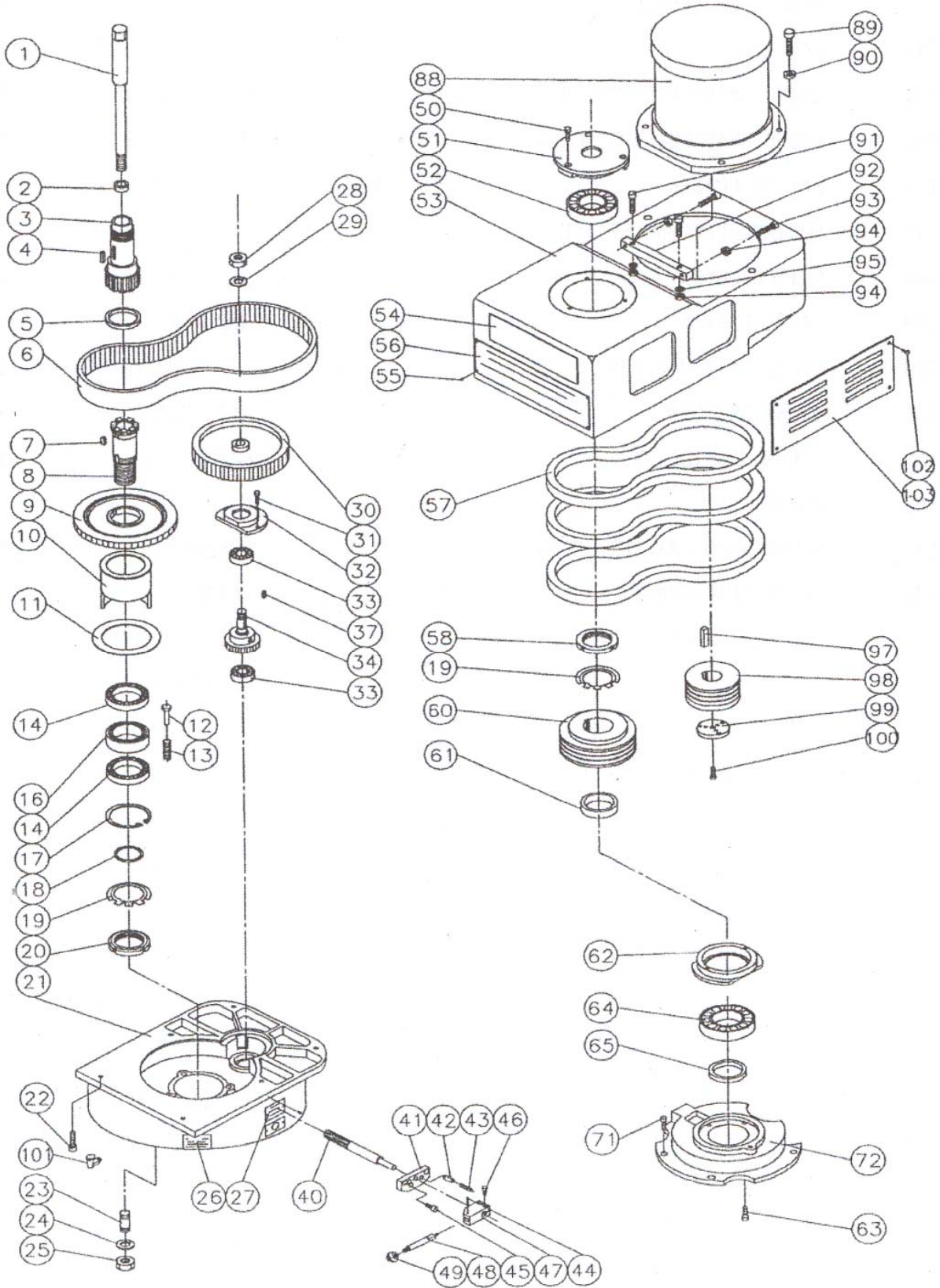

PARTS No.	DESCRIPTION	SPEC	QTY
VS-001	DRAW BAR		1
EVS-002	WASHER		1
EVS-003	PULLEY SHAFT		1
EVS-004	KEY	6*25L	1
EVS-005	COLLAR	Φ 54* Φ 48*6.5t	1
EVS-006	TIMEING BELT	225L-25W	1
EVS-007	KEY	8*12L	1
EVS-008	CLUTCH GEAR SHAFT		1
EVS-009	LARGE DRIVE GEAR		1
EVS-010	BEARING BUSHING		1
EVS-011	COLLAR		1
EVS-012	SPRING PLUNGER		3
EVS-013	SPRING		3
EVS-014	BEARING	6908 ZZ	2
EVS-016	BEARING SAPCER HOUSING		1
EVS-017	CIRCLIP	R62	1
EVS-018	SPACER WASHER		1
EVS-019	SPRING WASHER	M40	2
EVS-020	LOCK NUT		1
EVS-021	GEAR HOUSING		1
EVS-022	ROUND HEAD ALLEN SCREW	M8*20L	6
EVS-023	BOLT		3
EVS-024	SPRING WASHER	7/16"	3
EVS-025	HEXAGON NUT	7/16"	3
EVS-026	QUILL FEED PLATE	A-12	1
EVS-027	HIGH/LOW SPEED PLATE	S-5	1
EVS-028	HEXAGON NUT	5/8"*18NF*23	1
EVS-029	SPRING WASHER	5/8"	1
EVS-030	TOOTHED PULLEY		1
EVS-031	ROUND HEAD ALLEN SCREW	M5*16L	3
EVS-032	BEARING HOUSING		1
EVS-033	BEARING	6203 ZZ	2
EVS-034	GEAR SHAFT		1
EVS-037	KEY	5*15L	1
EVS-040	CLUTCH RING CONTROL SHAFT		1
EVS-041	HIGH/LOW SPEED PLATE		1
EVS-042	POSITIONING PIN		1
EVS-043	SPRING		1
EVS-044	SPRING PIN	Φ 3*18L	1
EVS-045	ROUND HEAD ALLEN SCREW	M6*12L	2
EVS-046	ROUND HEAD ALLEN SCREW	M5*12L	2

EVS-047	CHANGE GEAR HANDLE BLOCK		1
EVS-048	CLUTCH HANDLE		1
EVS-049	PLASTIC KNOB	1/4"	1
EVS-050	ROUND HEAD ALLEN SCREW	M6*20L	3
EVS-051	TOP BEARING COVER		1
EVS-052	BEARING	6007 ZZ	1
EVS-053	BELT HOUSING		1
EVS-054	NAME PLATE		1
EVS-055	RIVET	Φ 2*6L	10
EVS-056	SPINDLE SPEED PLATE		1
EVS-057	V'BELT	3V-300	3
EVS-058	LOCK NUT		1
EVS-060	FRONT PULLEY		1
EVS-061	BEARING RETAINER		1
EVS-062	BRAKE BEARING HOUSING		1
EVS-063	ROUND HEAD ALLEN SCREW	M6*12L	2
EVS-064	BEARING	6010 ZZ	1
EVS-065	BEARING RETAINER		1
EVS-071	ROUND HEAD ALLEN SCREW	M6*16L	4
EVS-072	BRAKE BASE		1
EVS-088	SPINDLE MOTOR		1
EVS-089	ALLEN HEAD SCREW	M10*40L	4
EVS-090	WASHER	Φ 10* Φ 30*2t	4
EVS-091	ROUND HEAD ALLEN SCREW	M8*40L	2
EVS-092	ADJUSTING BLOCK		1
EVS-093	ALLEN HEAD SCREW	M8*35L	2
EVS-094	HEXAGON NUT	M8	4
EVS-095	SPRING WASHER	M8	2
EVS-097	KEY	10*8*40L	1
EVS-098	MOTOR PULLEY		1
EVS-099	SET RING		1
EVS-100	ROUND HEAD ALLEN SCREW	M5*20L	3
EVS-101	OIL CUP	1/8"	1
EVS-102	ROUND HEAD ALLEN SCREW	3/16"*3/8"	8
EVS-103	COVER		2

7.8 Parts list of Lubrication system

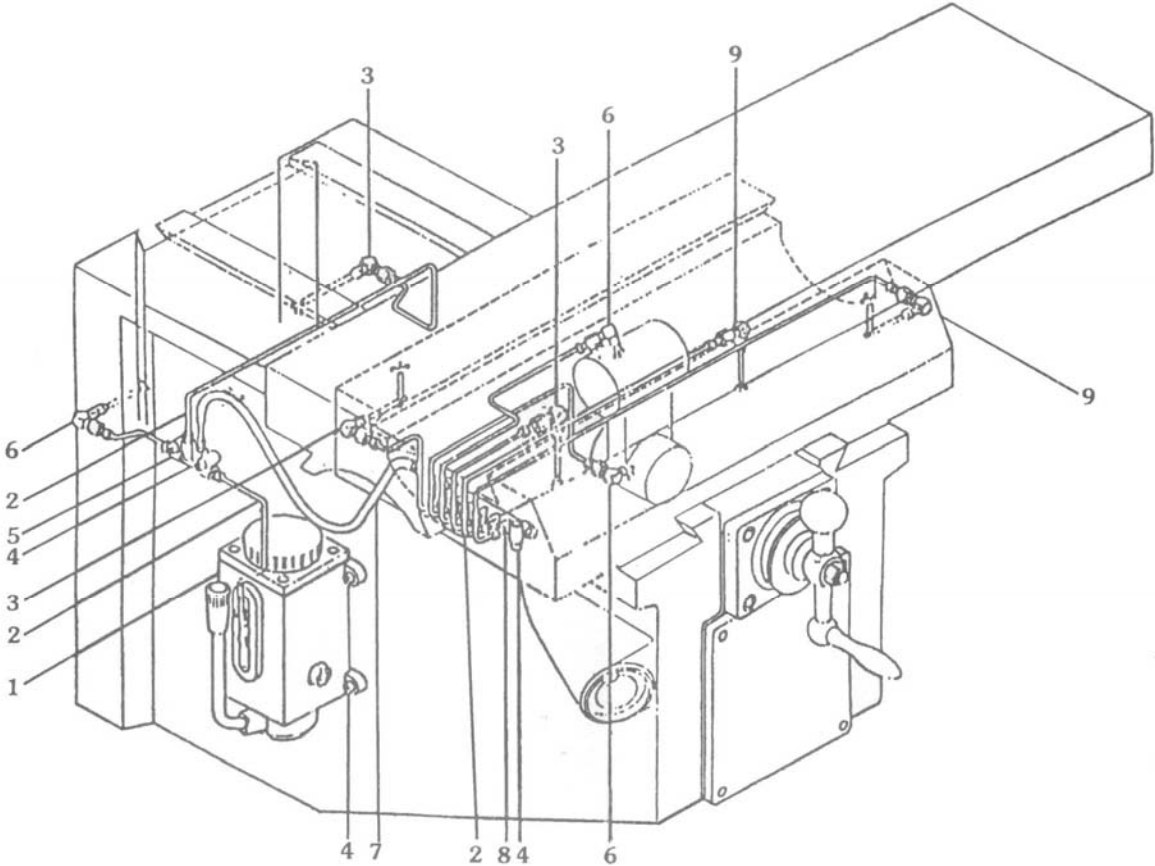

ITEM NO	DESCRIPTION	ITEM NO	DESCRIPTION
B001	Hand oil pump	E006	Ratio oil distributor
B002	Pipe Ø4	E007	Steel flexible tube
B003	Ratio oil distributor	E008	A type oil distributor
B004	screws	E009	Ratio oil distributor
B005	A type oil distributor		